

# TRIUMPH

## Trident

45 cu. ins. (750 c.c.)

# REPLACEMENT PARTS CATALOGUE

from Eng. No. T150.T. 101

Second Edition

TRIUMPH ENGINEERING COMPANY LIMITED  
MERIDEN WORKS · ALLESLEY · COVENTRY · ENGLAND  
TELEPHONE MERIDEN 331 TELEGRAMS "TRUSTY, COVENTRY"

# TRIUMPH GUARANTEE

1. In this Guarantee the word "machine" refers to the motor cycle, scooter, motor-cycle combination or sidecar as the case may be, purchased by the Purchaser.
2. In order to obtain the benefit of this Guarantee, the Purchaser must have correctly completed the registration form and returned it to us within fourteen days of the purchase.
3. We will supply, free of charge, a new part in exchange for, or, if we consider repair sufficient, will repair free of charge any part proved within six months of the date of purchase of any new machine, (3 months USA) or within three months of its renewal or repair in the case of a part already renewed or repaired, to be defective by reason of our faulty workmanship or materials. We do not undertake to bear the cost of fitting such new or repaired part or accessory.
4. Any part considered to be defective must be sent to our Distributor carriage paid, accompanied by the following information:—
  - (a) Name of purchaser and his address;
  - (b) Date of purchase of machine;
  - (c) Name of dealer from whom the purchase was made;
  - (d) Engine number and model.
5. This Guarantee shall not extend to defect or damage appearing after misuse, neglect, abnormal stress or strain, or the incorporation or affixing of unsuitable attachments or parts and in particular:—
  - (a) Hiring out;
  - (b) Racing and Competitions;
  - (c) Adaptation or alteration of any part or parts after leaving our Works;
  - (d) The attaching of a sidecar in a manner not approved by us or to an unsuitable motor-cycle.

This Guarantee shall not extend to machines whose trade mark, name or manufacturing number has been altered or removed, or in which has been used any part not supplied or approved by us, or to tyres, saddles, chains, speedometers, revolution counters and electrical equipment or to parts supplied to the order of the Purchaser and different from our standard specification.

6. Our liability and that of our dealer who sells the machine, shall be limited to that set out in this guarantee, and no other claims for consequential damage or injury to person or property, shall be admissible. All other conditions and warranties statutory or otherwise and whether express or implied are hereby excluded and no guarantee other than that expressly herein contained applies to the machine to which this Guarantee relates or any accessory or part thereof.
7. We reserve the right to modify or deviate from the Published Specification without notice.

## REPAIRS GUARANTEE

1. Whilst the highest standard of workmanship and materials is aimed at, we cannot accept liability for any defects appearing more than three months after the machine, assembly or component has left our Works after being repaired.
2. We will repair or replace at our option free of charge any defective work, materials or parts relating to the repairs carried out by us appearing within that time but shall not be under any further, or other liability for any other loss or damage whether direct or consequential and our liability shall be limited to the cost of so making good. We do not undertake to bear the cost of fitting any replacement or repaired part.
3. We do not accept liability in respect of parts of proprietary manufacture, e.g. tyres, saddles, chains, speedometers, revolution counters and electrical equipment which may be used by us in effecting a repair. All other conditions and warranties statutory or otherwise express or implied are hereby excluded.

Fig. No.	Description	Page No.
1	CRANKSHAFT AND CONNECTING RODS ... ..	8
2	CRANKCASES ... ..	10
3	OIL PUMP, RELEASE VALVE AND FILTER ... ..	12
4	CYLINDER HEAD AND ROCKER BOXES ... ..	14
5	CYLINDER BARREL, PUSH ROD AND TUBES, TAPPETS ... ..	16
6	TIMING COVER AND CONTACT BREAKER ... ..	18
7	MANIFOLD AND THROTTLE LINKAGE ... ..	20
8	GEARBOX OUTER COVER ... ..	22
9	GEARBOX INNER COVER AND SELECTORS ... ..	24
10	GEARBOX SHAFTS AND GEARS ... ..	26
11	CLUTCH AND CLUTCH OPERATING MECHANISM ... ..	28
12	INNER AND OUTER CHAINCASE ... ..	30
13	PRIMARY TRANSMISSION AND OIL PUMP DRIVE ... ..	32
14	FRAME ... ..	34
15	SWINGING FORK AND SUSPENSION UNITS ... ..	36
16	ENGINE UNIT FITTINGS AND FOOTRESTS ... ..	38
17	EXHAUST PIPES AND SILENCERS (MUFFLERS) ... ..	40
18	TELESCOPIC FRONT FORK ... ..	42
19	HANDLEBAR MOUNTINGS AND STEERING DAMPER ... ..	44
20	FRONT WHEEL ... ..	46
21	FRONT WHEEL ... ..	48
22	REAR WHEEL ... ..	50
23	OIL COOLER ... ..	52
24	PETROL (GAS) TANK ... ..	54
25	OIL TANK ... ..	56
26	BATTERY CARRIER AND AIR FILTER ... ..	58
27	PANELS AND TWINSEAT ... ..	60
28	MUDGUARDS (FENDERS) ... ..	62
29	MUDGUARDS (FENDERS) ... ..	64
30	HANDLEBARS, CONTROLS, BINNACLE AND OIL WARNING LIGHT ... ..	66
31	CONTROL CABLES ... ..	68
32	TOOLKIT AND PILLION FOOTRESTS ... ..	70
33	AMAL CARBURETTER ... ..	72
34	SPEEDOMETER AND TACHOMETER ... ..	74
35	IGNITION COILS, HORNS, RECTIFIER AND ZENER DIODE ... ..	76
36	HEADLAMP, WIRING HARNESS, SWITCHES AND TAIL LAMP ... ..	78

## PROPRIETARY GROUP

Ancillary equipment which is fitted to our motor cycles is of the highest quality and is guaranteed by the manufacturers and not by ourselves. Any repairs or claims should be directed to the actual makers or their local agents who will always give owners every possible assistance. The following are the addresses of the various manufacturers:—

### CARBURETTERS.

Messrs. Amal Ltd.,  
Holdford Road,  
Witton,  
Birmingham, 6.

### CHAINS.

Renold Chains Ltd.,  
Wythenshawe,  
Manchester.

### ELECTRICAL EQUIPMENT.

Messrs. J. Lucas Ltd.,  
Gt. Hampton Street,  
Birmingham, 18.

### TYRES.

Dunlop Rubber Co. Ltd.,  
Fort Dunlop,  
Birmingham, 24.

The Avon Rubber Co. Ltd.,  
Melksham,  
Wilts.

### SPARKING PLUGS.

Champion Sparking Plug Co. Ltd.,  
Feltham,  
Middlesex.

### SPEEDOMETERS.

Messrs. Smiths Industries Ltd.,  
Cricklewood Works,  
London, N.W.2.

### SUSPENSION UNITS.

Messrs. Girling Ltd.,  
Birmingham Road,  
West Bromwich,  
Staffordshire.

	Page		Page
AIR FILTER ... ..	59	KICKSTARTER ... ..	23
ALTERNATOR ... ..	19	MANIFOLD ... ..	21
AUTO-ADVANCE UNIT ... ..	19	MUDGUARDS ... ..	63, 65
AMMETER ... ..	67	MUFFLERS ... ..	41
BATTERY CARRIER ... ..	59	OIL COOLER ... ..	53
BINNACLE ... ..	67	OIL PUMP ... ..	13
BRAKE SWITCHES ... ..	77	OIL TANK ... ..	57
CAMSHAFT, INLET AND EXHAUST	9	OIL FILTER ... ..	13
CAPACITOR, IGNITION ... ..	77	OVERSIZE PARTS ... ..	7
CARBURETTER ... ..	73	PETROL TANK ... ..	55
CENTRE STAND ... ..	35	PISTONS ... ..	9
CHAINS ... ..	33	PROP STAND ... ..	35
CHAINCASE ... ..	31	PUSH RODS ... ..	17
CLUTCH ... ..	29	REAR WHEEL ... ..	51
CLUTCH LEVER ASSEMBLY ... ..	67	RECTIFIER ... ..	77
COIL ... ..	77	REFLECTORS ... ..	53, 63, 65
CONDENSER PACK ... ..	77	ROCKERS ... ..	15
CONNECTING RODS ... ..	9	SIDE PANEL ... ..	61
CONTACT BREAKER ... ..	19	SILENCERS ... ..	41
CONTROL CABLES ... ..	69	SPARK PLUG ... ..	77
CONTROL LEVERS ... ..	67	SPEEDOMETER ... ..	75
CRANKCASE ... ..	11	SPEEDOMETER GEARBOX ... ..	51
CRANKSHAFT ... ..	9	STEERING DAMPER ... ..	45
CYLINDERS ... ..	17	STEERING RACES ... ..	35, 43
CYLINDER HEAD ... ..	15	SUSPENSION UNITS ... ..	37
ENGINE PLATES ... ..	39	SWINGING FORK ... ..	37
ENGINE TORQUE STAY ... ..	39	SWITCHES ... ..	77
EXHAUST PIPES ... ..	41	TACHOMETER ... ..	75
EXHAUST PIPE ADAPTOR ... ..	15	TACHOMETER GEARBOX ... ..	75
FENDERS ... ..	63, 65	TAIL LAMP ... ..	77
FOOTRESTS ... ..	39	TAPPETS ... ..	17
FRAME ... ..	35	TIMING GEARS ... ..	9
FRONT BRAKE... ..	47, 49	TOOLKIT ... ..	71
FRONT BRAKE LEVER ... ..	67	TWIN SEAT ... ..	61
FRONT FORKS ... ..	43	VALVES ... ..	15
FRONT WHEEL ... ..	47, 49	VALVE GUIDES ... ..	15
GASKET SET ... ..	7	WARNING LIGHTS ... ..	67
GAS TANKS ... ..	55	WIRING HARNESS ... ..	79
GEARBOX ... ..	23, 25, 27	ZENER DIODE ... ..	77
HANDLEBARS ... ..	67		
HANDLEBAR MOUNTINGS ... ..	45		
HEADLAMP ... ..	79		
HEAT SINK ... ..	77		
HORN ... ..	77		

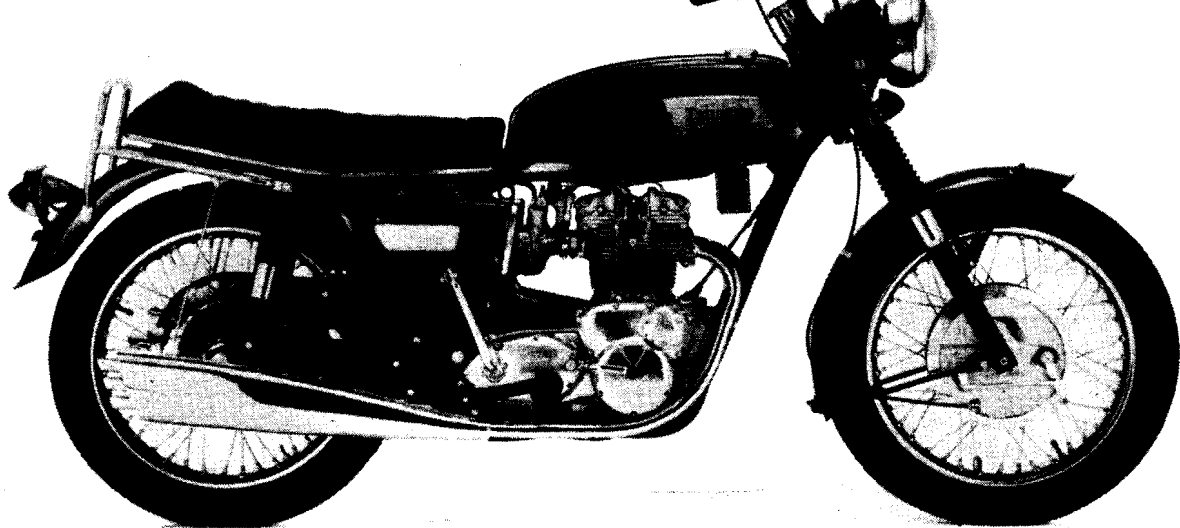

### TRIDENT (T150) TECHNICAL DATA

<b>Bore and stroke...</b>	...	...	...	...	...	...	...	...	...	67 x 70 mm. 2.67 x 2.751 ins.
<b>Capacity ...</b>	...	...	...	...	...	...	...	...	...	741 c.c. (45 cu. ins.)
<b>Compression ratio</b>	...	...	...	...	...	...	...	...	...	9.5 : 1
<b>Spark plugs</b>	...	...	...	...	...	...	...	...	...	Champion N3
<b>Carburetors</b>	...	...	...	...	...	...	...	...	...	3 Amal Concentric 626
				Main jet	...	...	...	...	...	150
				Needle jet	...	...	...	...	...	-106
				Throttle valve	...	...	...	...	...	No. 3
<b>Gearbox sprocket</b>	...	...	...	...	...	...	...	...	...	19 teeth
<b>Chains</b>	...	...	...	Front	...	...	...	...	...	$\frac{3}{8}$ " Triplex x 82 links
				Rear	...	...	...	...	...	$\frac{5}{8}$ " x $\frac{1}{8}$ " x 106 links
<b>Capacities</b>	...	...	...	Gas Tank	...	...	...	...	...	4 $\frac{1}{4}$ U.S. galls. (15.94 litres)
				Oil Tank	...	...	...	...	...	5 U.S. pints (2.8 litres)
				Gearbox...	...	...	...	...	...	1 $\frac{1}{3}$ pints (750 c.c.)
				Primary Chaincase	...	...	...	...	...	$\frac{3}{8}$ pint (350 c.c.)
				Front Forks (each leg)	...	...	...	...	...	$\frac{1}{3}$ pint (200 c.c.)
<b>Brakes</b>	...	...	...	Front, diameter...	...	...	...	...	...	8" (20.32 cm.)
				Rear, diameter	...	...	...	...	...	7" (17.78 cm.)
<b>Tire size</b>	...	...	...	Front	...	...	...	...	...	3.50 x 19 ins.
				Rear	...	...	...	...	...	4.10 x 19 ins.
<b>Color</b>	...	...	...	...	...	...	...	...	...	Aquamarine

First check that the engine number of your machine is subsequent to that quoted on the title page.

Next consult the index on Page 4 for the parts or group of parts which you wish to locate. When you have located the parts make sure from the end columns that the part you have located does apply to your machine.

List the quantities required as single units; do not ask for "2 pairs" or "3 dozen".

In case of painted items always state the color required. Painted parts are available only in the colours or alternatives specified for that model of that particular year.

<i>Model</i>	<i>Color</i>
T150	Aquamarine

N.B. Aquamarine is a metallic finish requiring no special undercoat.

Paint is available only in Aerosol containers.

#### **PLEASE NOTE**

THROUGHOUT THIS LIST, ASSEMBLIES ARE PRINTED IN CAPITALS AND THE COMPONENTS INCLUDED IN THAT ASSEMBLY ARE INDENTED IN THE DESCRIPTION COLUMN, REVERTING TO THE ORIGINAL ALIGNMENT WHEN THE ASSEMBLY IS COMPLETE. TO ORDER THE COMPLETE ASSEMBLY IT IS NECESSARY ONLY TO QUOTE THE ASSEMBLY NUMBER. ANY COMPONENT PARTS LISTED MAY ALSO BE OBTAINED SEPARATELY IF REQUIRED.

#### **SPECIAL WORKSHOP TOOLS**

A COMPLETE LIST OF WORKSHOP TOOLS CAN BE MADE AVAILABLE BY EITHER CONTACTING YOUR DEALER OR APPLYING DIRECT TO THE TRIUMPH SERVICE DEPARTMENT. IN MOST CASES THESE TOOLS ARE VERY COSTLY AS THEY ARE MADE ENTIRELY FOR WORKSHOP USE, AND THEREFORE, IT IS NOT RECOMMENDED THAT THE PRIVATE OWNER PURCHASES THE TOOLS IN ORDER TO AID SERVICING THE MACHINE ONCE OR TWICE ONLY. IN THESE CIRCUMSTANCES IT IS FAR MORE ECONOMICAL TO GET IN TOUCH WITH A RECOGNISED DEALER.

**PISTONS (Complete with rings, gudgeon pins and circlips)**

These are in effect "carton pack" assemblies

Compression ratio 9.5 : 1	{	E9741 Std. E9762+10 E9763+20 E9764+40
---------------------------	---	--

**PISTON RINGS**

CP212	{	2 off E6838 Compression ring 1 off E6839 Scraper ring	} Std.
CP212/10	{	2 off E9016 Compression ring 1 off E9766 Scraper ring	} +10
CP212/20	{	2 off E9017 Compression ring 1 off E9767 Scraper ring	} +20
CP212/40	{	2 off E9018 Compression ring 1 off E9768 Scraper ring	} +40

**BIG END BEARINGS SHELLS**

	E5998 Shell Std.
	E9023 Shell —10
	E9024 Shell —20
	E9025 Shell —30
	E9026 Shell —40
Decoke Gasket Set	99-0039
Overhaul Gasket Set	99-0030

**MAIN BEARING SHELLS**

E9027—·010 in. undersize  
 E9028—·020 in. undersize  
 E9029—·030 in. undersize  
 E9030—·040 in. undersize

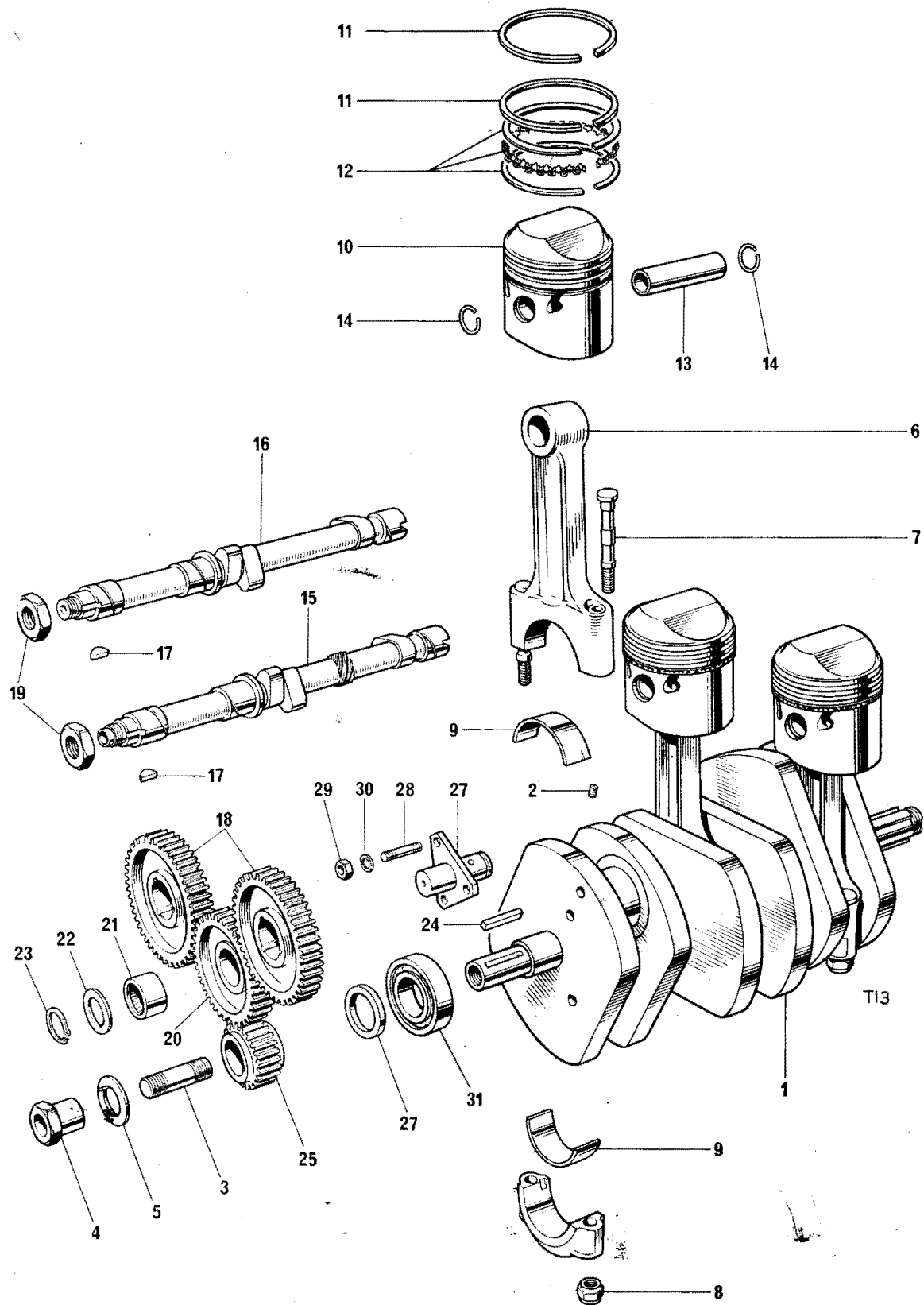

**Fig. 1. CRANKSHAFT AND CONNECTING RODS**



## CRANKSHAFT AND CONNECTING RODS

1	E8778	CRANKSHAFT ASSEMBLY ...	1
2	E6577	Oilway plug ...	4
3	S548	Alternator stud (1 $\frac{3}{8}$ in. O.A.) ...	1
4	E8763	Rotor nut ...	1
5	E3975	Washer ...	1
6	E9740	CON ROD ASSEMBLY ...	3
7	E9727	Bolt con rod ...	6
8	S549	Nut, con rod ...	6
9	E5998	*Bearing, big end ...	3
10	E9741	†PISTON ASSEMBLY ...	3
11	E6838	‡Taper piston ring ...	6
12	E9739	Scraper ring ...	3
13	E6836	Gudgeon pin ...	3
14	E6840	Circlip ...	6
15	E8765	Exhaust camshaft ...	1
16	E8764	Inlet camshaft ...	1
17	E1558	Key, camshaft ...	2
18	E9802	Pinion camshaft ...	2
19	E6523	Nut, camshaft ...	2
20	E6029	Intermediate timing gear ...	1
21	E7650	Needle roller bearing ...	1
22	E6088	Thrust washer ...	1
23	E8768	Circlip ...	1
24	E10037	Key—timing pinion and rotor ...	1
25	E6524	Timing pinion ...	1
26	E6173	Distance piece ...	1
27	E6030	Spindle, intermediate gear ...	1
28	S547	Stud ( $\frac{7}{8}$ in. O.A.) ...	1
29	14-0401	Nut, intermediate gear ...	1
30	S26-2	Washer ...	1
31	E8780	Main bearing (roller) ...	1

\* Available in undersizes of -0.010", 0.020", 0.030", 0.040"

† Available in oversizes of +0.010", 0.020", 0.040"

‡ Available in oversizes of +0.010, 0.020", 0.040"

} See page 7

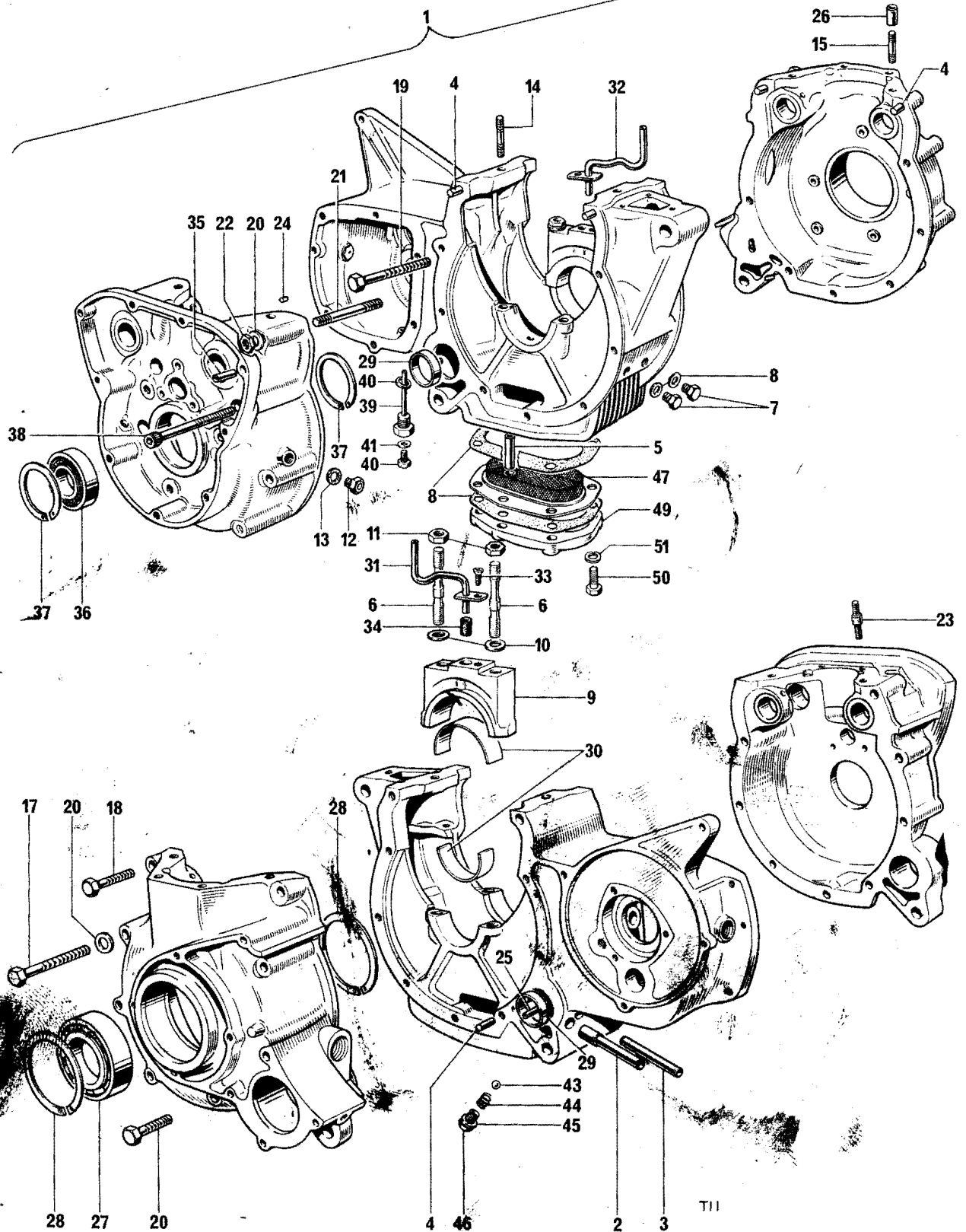
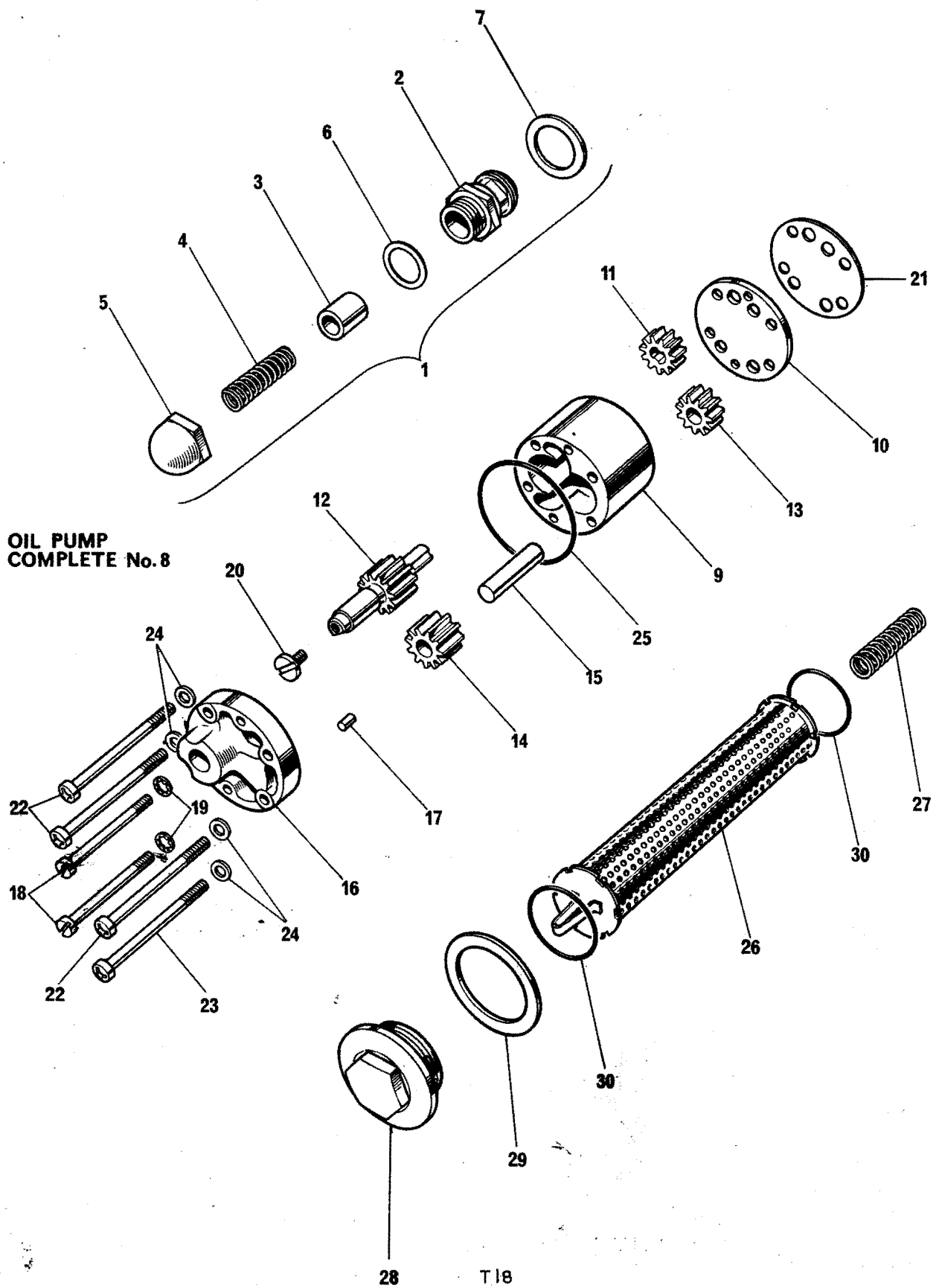

Fig. 2. CRANKCASES

### CRANKCASES

1	E9002	CRANKCASES ... ..	1	
2	E6573	Oil return pipe stub ... ..	1	
3	E6574	Oil feed pipe stub ... ..	1	
4	E8774	Dowel T.S. and D.S. ... ..	4	
5	E6578	Scavenge tube ... ..	1	
6	E8745	Waisted stud, main bearing cap ... ..	4	
7	14-6113	Plug, main bearing oilways ( $\frac{3}{8}$ in. U.H.) ... ..	2	
8	E8776	Washer ... ..	2	
9	E7423	Cap, main bearing ... ..	2	
10	S25-2	Washer ... ..	4	
11	14-1203	Nut ... ..	4	
12	E8755	Plug, timing aperture ... ..	1	
13	E1523	Washer, timing aperture ... ..	1	
14	S1931	Stud, cylinder base ( $1\frac{1}{2}$ in. O.A.) ... ..	4	
15	E8738	Stud, cylinder at dowel ( $1\frac{1}{2}$ in. O.A.) ... ..	2	
16	14-6218	Clamping bolt ( $1\frac{3}{8}$ in. U.H.) ... ..	2	
17	14-6226	Clamping bolt ( $3\frac{1}{4}$ in. U.H.) ... ..	9	
18	14-6220	Clamping bolt ( $1\frac{1}{2}$ in. U.H.) ... ..	2	
19	14-6223	Clamping bolt ( $2\frac{1}{4}$ in. U.H.) ... ..	1	
20	S25-3	Washer ... ..	9	
21	14-1427	Stud, T.S. crankcase (3 in. O.A.) ... ..	2	
22	14-0302	Nut ... ..	2	
23	S1912	Stud, cylinder ( $1\frac{1}{2}$ in. O.A.) ... ..	4	
24	T912	Peg, needle roller thrust ... ..	1	
25	E1532	Dowel, oil pump to crankcase ... ..	1	
26	E8751	Dowel, cylinder base ... ..	2	
27	E1591	D.S. main bearing ... ..	1	
28	E6025	Circlip, main bearing ... ..	2	
29	E9586	Sleeve at 'O' ring ... ..	2	
30	E6033	Main Bearing Shell (see Page 7 also) ... ..	4	
31	E8748	Tappet oil feed pipe T.S. ... ..	1	
32	E8746	Tappet oil feed pipe D.S. ... ..	1	
33	T1150	Screw, pipe to bearing cap ... ..	2	
34	E9843	Sealing rubber ... ..	4	
35	T989	Dowel ... ..	2	
36	E8780	Main bearing T.S. (roller) ... ..	1	
37	E6026	Circlip ... ..	2	
38	S678	Socket screw (4 in. U.H.) ... ..	1	
39	T3851	Gearbox drain plug ... ..	1	
40	E2441	Fibre washer ... ..	1	
41	S543	Level plug ... ..	1	
42	T1257	Fibre washer ... ..	1	
43	E8750	Non return valve ball ( $\frac{7}{8}$ in. dia.) ... ..	1	
44	E6567	Spring ... ..	1	
45	E6742	Joint washer ... ..	1	
46	E6584	Plug ... ..	1	
47	E6501	Scavenge filter ... ..	1	
48	E6516	Gasket ... ..	2	
49	E6580	Cover ... ..	1	
50	14-6103	Bolt ( $\frac{3}{8}$ in. U.H.) ... ..	6	
51	S26-2	Spring washer ... ..	4	

**OIL PUMP  
COMPLETE No. 8**



**Fig. 3. OIL PUMP, RELEASE VALVE AND FILTER**

## OIL PUMP RELEASE VALVE AND OIL FILTER

Ref. No.	Part No.	Description	Quantity	Remarks
1	E6595	OIL PRESSURE RELEASE VALVE ... ..	1	
2	E7590	Body ... ..	1	
3	GS251	Piston ... ..	1	
4	E7591	Spring ... ..	1	
5	E6596	Cap ... ..	1	
6	E9738	Joint washer (cap to body) ... ..	1	
7	E9737	Alloy washer ... ..	1	
8	E9001	OIL PUMP COMPLETE ... ..	1	
9	E6430	Oil pump, body ... ..	Not serviced	
10	E6502	Base plate ... ..	1	
11	E6455	Drive feed gear ... ..	1	
12	E6889	Drive scavenge gear ... ..	1	
13	E6038	Driven feed gear ... ..	1	
14	E6039	Driven scavenge gear ... ..	1	
15	E6454	Driven gear spindle ... ..	1	
16	E6525	Cover ... ..	1	
17	E6459	Dowel, cover to body ... ..	1	
18	S559	Screw, cover to body (2 in. U.H.) ... ..	2	
19	E8731	Washer, cover to pump screw ... ..	2	
20	E7250	Screw, pinion to drive gear ( $\frac{3}{8}$ in. U.H.) ... ..	1	
21	E6503	Gasket, oil pump to crankcase ... ..	1	
22	E10003	Screw, pump to crankcase ( $2\frac{1}{2}$ in. U.H.) ... ..	3	
23	E9601	Screw, pump to crankcase at dowel ( $2\frac{3}{4}$ in. U.H.) ... ..	1	
24	E8732	Washer, pump to crankcase ... ..	3	
25	E6570	Seal, pump to crankcase ... ..	2	
26	E6571	Oil filter element ... ..	1	
27	E6130	Spring ... ..	1	
28	E6582	Cap ... ..	1	
29	E6131	Fibre washer ... ..	1	
30	E8779	Filter seal ... ..	2	

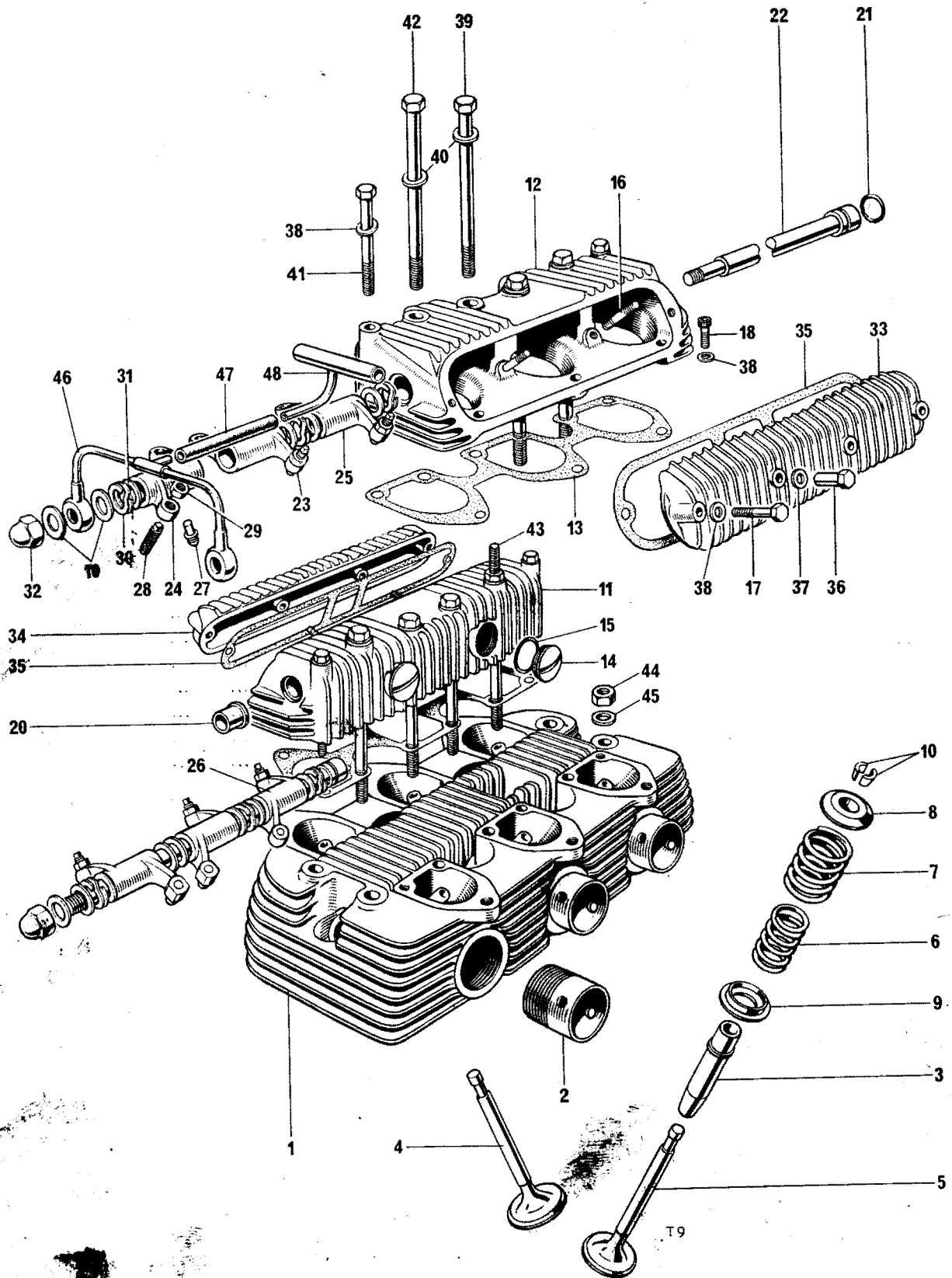

**Fig. 4. CYLINDER HEAD AND ROCKER BOXES**

## CYLINDER HEAD AND ROCKER BOXES

Ref. No.	Part No.	Description	Quantity	Remarks
1	E8781	CYLINDER HEAD	1	
2	E9510	Exhaust pipe adaptor	3	
3	E6420	Valve guide	6	
4	E6422	Inlet valve	3	
5	E6423	Exhaust valve	3	
6	E8787	Inner, valve spring	6	
7	E8788	Outer valve spring	6	
8	E8720	Top collar	6	
9	E8789	Bottom cup	6	
10	99-0062	Split cotter	12	
11	E6561	Inlet rocker box	1	
12	E6562	Exhaust rocker box	1	
13	E8773	Rocker box gasket	2	
14	T2166	Rocker box cap	4	
15	E8782	"O" ring cap	4	
16	14-1401	Stud, rocker box cover (1 in. O.A.)	4	
17	14-0201	Bolt, rocker box cover (1 in. U.H.)	4	
18	14-7004	Screw	6	
19	E1335	Copper washer	4	
20	E6018	Bush, T.S. for rocker spindle	2	
21	E3253	"O" ring, D.S. bush	2	
22	E9558	Rocker spindle	2	
23	E9779	ROCKER LEVER, T.S. INLET/CENTRE EXHAUST	2	
24	E9780	ROCKER LEVER, T.S. EXHAUST/CENTRE INLET	2	
25	E9782	ROCKER LEVER, EXHAUST D.S.	1	
26	E9781	ROCKER LEVER, INLET D.S.	1	
27	E7651	Ball pin	6	
28	E8783	Adjusting pin	6	
29	14-0402	Locknut	6	
30	E1574	Thackeray washer	6	
31	E1575	Plain washer	12	
32	S550	Dome nut	2	
33	E6564	Inspection cover, exhaust	1	
34	E6563	Inspection cover, inlet	1	
35	E6565	Gasket	2	
36	E9237	Sleeve nut	4	
37	E9239	Plain washer	4	
38	S25-1	Washer	8	
39	E8820	Bolt, short rockerbox to barrel ( $\frac{5}{16}$ " x $4\frac{1}{4}$ " )	4	
40	E9240	Washer	8	
41	14-6211	Bolt, rocker box to head (3 in. U.H.) ( $\frac{1}{4}$ " x 3")	4	
42	E8819	Bolt, long rocker box to barrel ( $\frac{5}{16}$ " x $4\frac{1}{2}$ " )...	2	
43	E10280	Bolt, torque stay, rocker box to barrel ( $5\frac{1}{2}$ in.)	2	
44	14-0303	Nut	4	
45	F2184	Washer	4	
46	E9274	Rocker pipe	1	
47	E6353	Connecting tube	1	
48	E9271	Oil feed pipe	1	
49	S550	Dome nut	2	

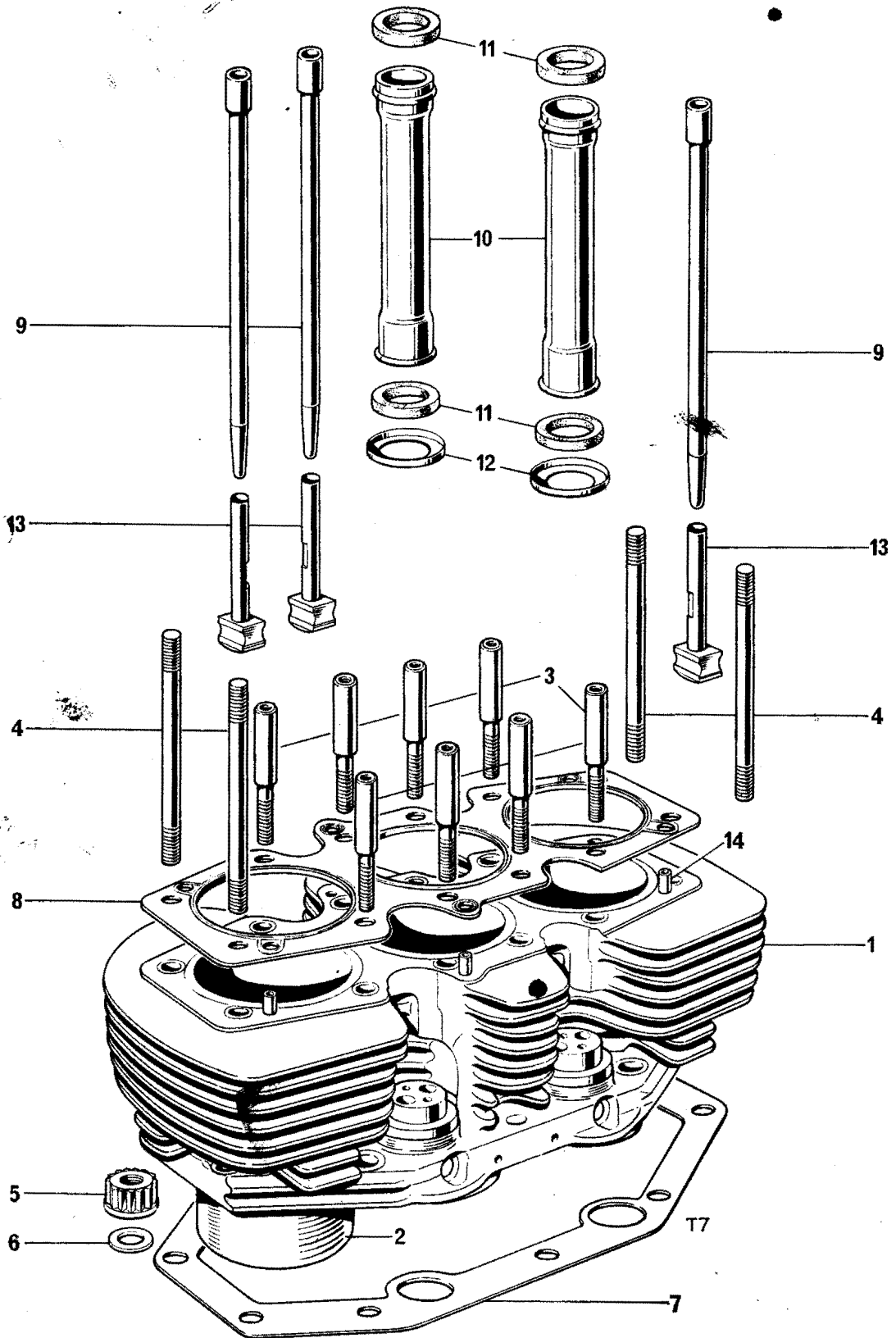
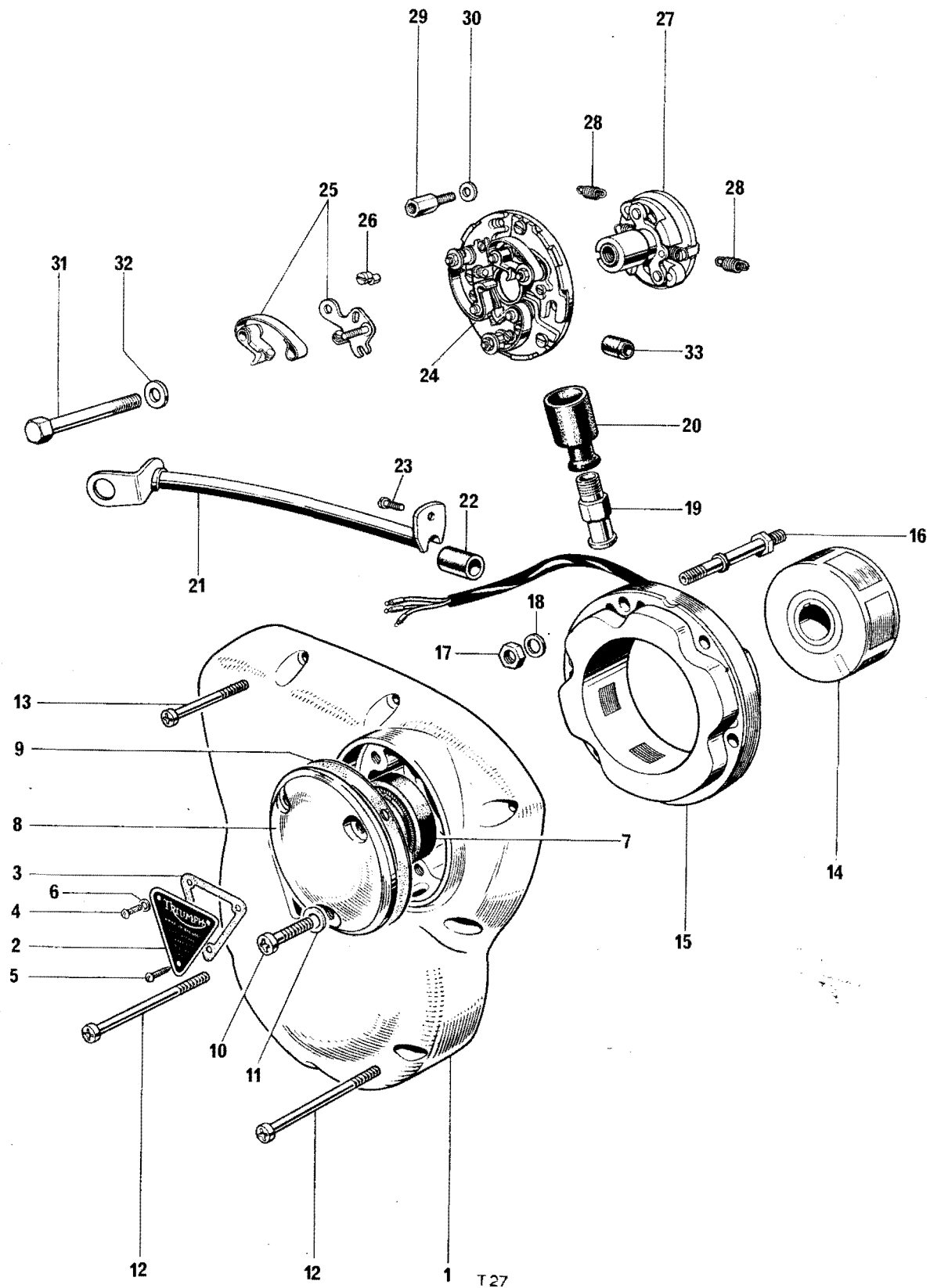

Fig. 5. CYLINDER BARREL, PUSH ROD AND TUBES, TAPPETS



## CYLINDER BARREL, PUSH RODS AND TUBES, TAPPET BLOCKS

1	E6529	CYLINDER BARREL C/W LINERS	...	...	...	...	...	1
2	E8914	Cylinder liner	...	...	...	...	...	3
3	E8817	Pillar stud	...	...	...	...	...	8
4	S686	Stud, barrel to head ( $4\frac{5}{8}$ in. O.A.)	...	...	...	...	...	4
5	S692	Base nut (12 point)	...	...	...	...	...	10
6	GS308	Washer	...	...	...	...	...	10
7	E6496	Cylinder base gasket	...	...	...	...	...	1
8	E9972	Cylinder head gasket	...	...	...	...	...	1
9	E6506	Push rod	...	...	...	...	...	6
10	E6955	Push rod tube	...	...	...	...	...	4
11	E4752	Sealing rubber	...	...	...	...	...	8
12	E4746	Bottom cup	...	...	...	...	...	4
13	E8917	Tappet	...	...	...	...	...	6
14	E1532	Dowel	...	...	...	...	...	6



**Fig. 6. TIMING COVER AND CONTACT BREAKER**

## TIMING COVER AND CONTACT BREAKER

Ref. No.	Part No.	DESCRIPTION	QUANTITY	REMARKS
1	E6432	Timing cover . . . . .	1	
2	E8762	Cover, timing aperture . . . . .	1	
3	E8761	Joint washer . . . . .	1	
4	E10007	Screw ( $\frac{5}{16}$ in. U.H.) . . . . .	2	
5	E10006	Pointer screw . . . . .	1	
6	E9266	Washer . . . . .	3	
7	E4568	Oil seal . . . . .	1	
8	E6519	C:B. cover . . . . .	1	
9	E6572	Gasket C:B. cover . . . . .	1	
10	F4715	Screw ( $\frac{13}{32}$ in. U.H.) . . . . .	3	
11	GS299	Washer . . . . .	3	
12	14-6612	Screw (2" U.H.) . . . . .	3	
13	14-6608	Screw (1" U.H.) . . . . .	6	
14	99-1012	Rotor 54210937 . . . . .	1	
15	99-1016	Stator 47209 . . . . .	1	
16	E6522	Stud, alternator mounting . . . . .	3	
17	S677	Nut, alternator mounting . . . . .	3	
18	S25-3	Washer . . . . .	3	
19	E8760	Cable seal nut . . . . .	1	
20	E4144	Grommet . . . . .	1	
21	E8757	Cover, alternator leads . . . . .	1	
22	E8756	Rubber ferrule . . . . .	1	
23	H916	Screw, lead cover to crankcase ( $\frac{5}{16}$ in. U.H.) . . . . .	1	
24	99-1013	CONTACT BREAKER 7CA 54419327 . . . . .	1	
25	99-1014	Contact set 54419828 . . . . .	3	
26	99-0769	Adjusting screw 54419220 . . . . .	3	
27	99-1015	AUTO ADVANCE UNIT 54419867 . . . . .	1	
28	99-0757	Spring 54415642 . . . . .	2	
29	E6521	Pillar bolt . . . . .	3	
30	E6559	Washer . . . . .	3	
31	14-0208	Bolt C.B. cam to camshaft ( $2\frac{1}{4}$ " U.H.) . . . . .	1	
32	S25-43	Washer . . . . .	1	
33	E8756	Grommet . . . . .	1	

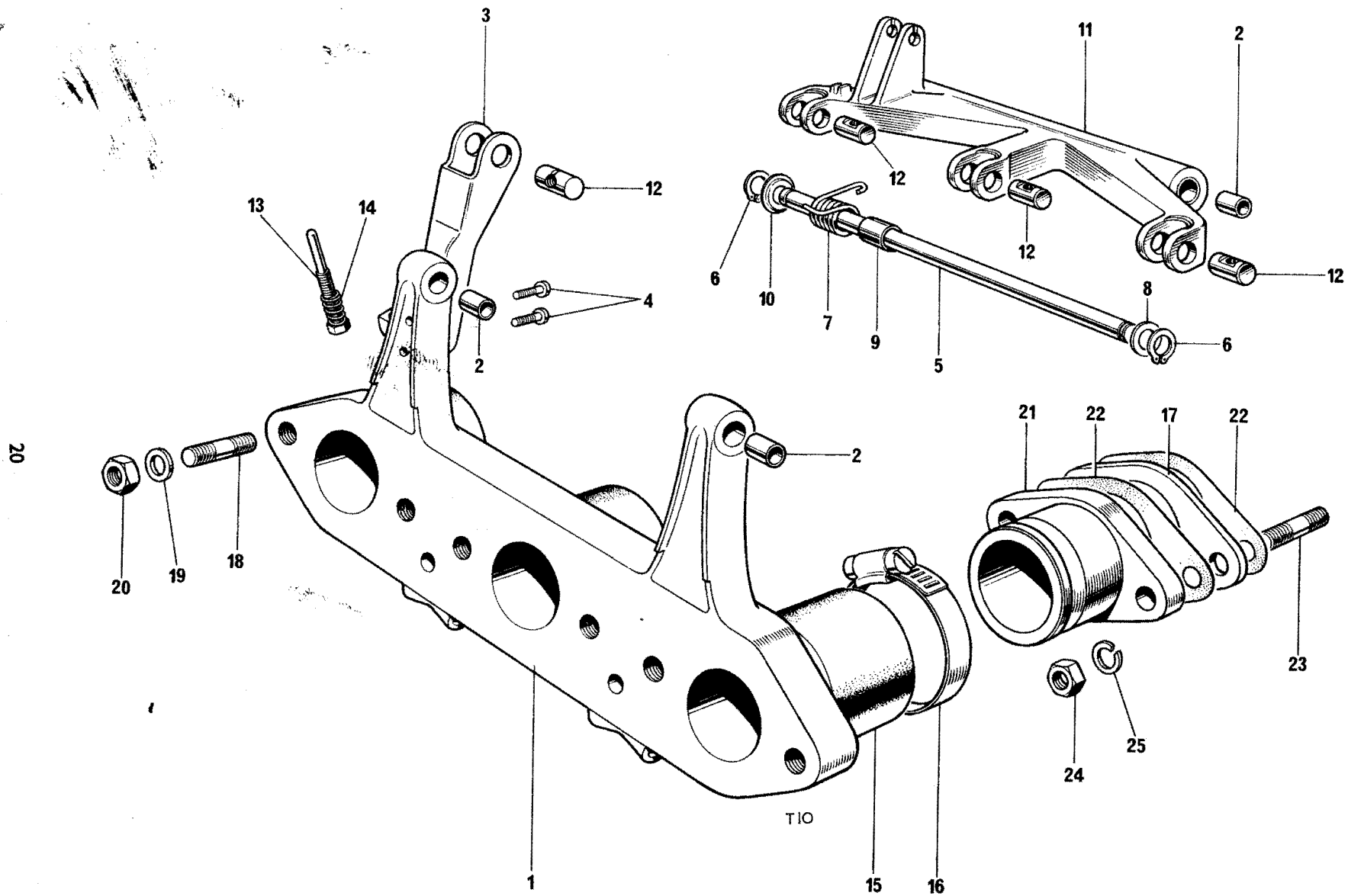

Fig. 7. MANIFOLD AND THROTTLE LINKAGE

Ref. No.	Part No.	DESCRIPTION	QUANTITY	REMARKS
<b>MANIFOLD AND THROTTLE LINKAGE</b>				
1	E7633	ADAPTOR c/w BUSHES	1	
2	E9073	Bush	4	
3	E9242	Support arm	1	
4	S774	Screw self-tapping ( $\frac{5}{16}$ in. U.H.)	2	
5	E9251	Spindle	1	
6	E9255	Circlip	2	
7	E9880	Return spring	1	
8	F10245	Washer	1	
9	E9820	Spacer	1	
10	E9821	Retaining cup	1	
11	E9241	Operating arm	1	
12	E9243	Trunnion	4	
13	E9252	Screw	1	
14	E9254	Spring	1	
15	E9060	Rubber sleeve	3	
16	D707	Jubilee type clip	6	
17	E8981	Insulating block	3	
18	S673	Stud carburetter ( $1\frac{1}{4}$ " O.A.)	6	
19	S25-3	Washer	6	
20	14-0302	Nut, carburetter fixing	6	
21	E9057	Stub, cylinder head	3	
22	E8784	Joint washer, stub to head	3	
23	S557	Stud ( $1\frac{5}{32}$ " O.A.)	6	
24	14-0301	Nut, cylinder head	6	
25	S25-13	Washer	6	

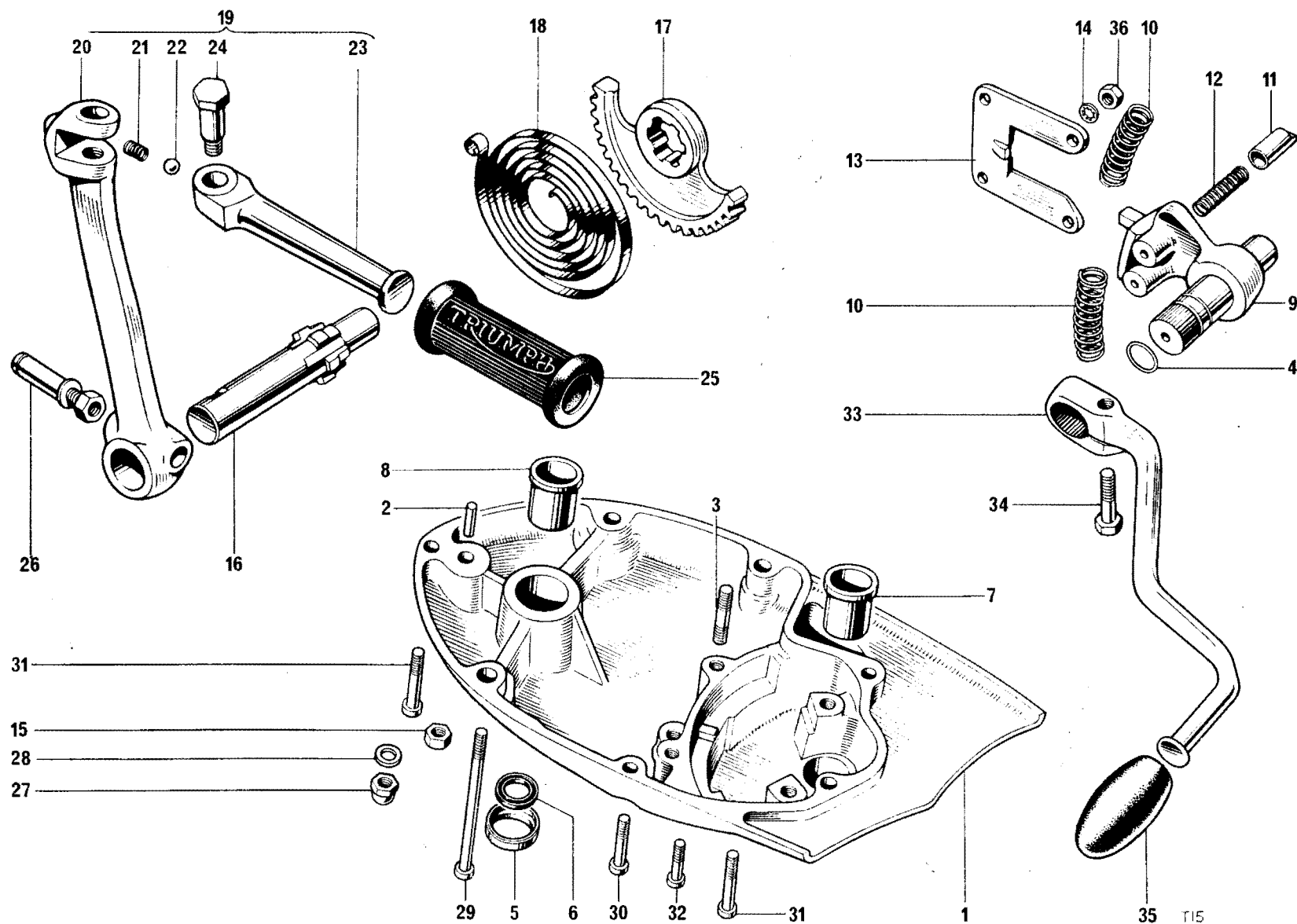

Fig. 8. GEARBOX OUTER COVER

## GEARBOX OUTER COVER

Ref. No.	Part No.	Description	Quantity	Remarks
1	T3750	GEARBOX OUTER COVER	1	
2	T47	Kickstart anchor peg	1	
3	S547	Stud guide plate ( $\frac{7}{8}$ in. O.A.)	4	
4	E3309	Sealing Ring	1	
5	T1955	Housing, oil seal	1	
6	T1956	Oil seal	1	
7	T57	Bush (F/C Spindle)	1	
8	T23	Bush (K/S Spindle)	1	
9	T408/9	Plunger quadrant	1	
10	T404	Spring	2	
11	T406	Plunger	2	
12	T405	Spring	2	
13	T407	Guide plate	1	
14	E1612	Washer	4	
15	14-0302	Nut	4	
16	T24A	Kickstart axle shaft	1	
17	T2169	Kickstart quadrant	1	
18	T31	Kickstart return spring	1	
19	T3632	FOLDING KICKSTART COMPLETE	1	
20	T2173	Crank	1	
21	T1167	Spring	1	
22	S70-3	Ball, $\frac{1}{4}$ in. dia.	1	
23	T1272	Pedal	1	
24	S541	Pivot bolt	1	
25	T2330	Rubber	1	
26	T1222	Cotter pin c/w nut and washer (nut only F879)	1	
27	S544	Domed nut outer cover	2	
28	S25-3	Washer	2	
29	S1815	Screw, outer cover long ( $4\frac{1}{4}$ " U.H.)	1	
30	14-6609	Screw, outer cover ( $1\frac{1}{4}$ " U.H.)	1	
31	14-6610	Screw, outer cover ( $1\frac{1}{2}$ " U.H.)	2	
32	14-6608	Screw, outer cover (1" U.H.)	1	
33	T3751	Gearchange pedal	1	
34	14-0201	Pinch bolt ( $1\frac{1}{2}$ in. U.H.)	1	
35	T2450	Rubber	1	
36	14-0301	Nut	4	

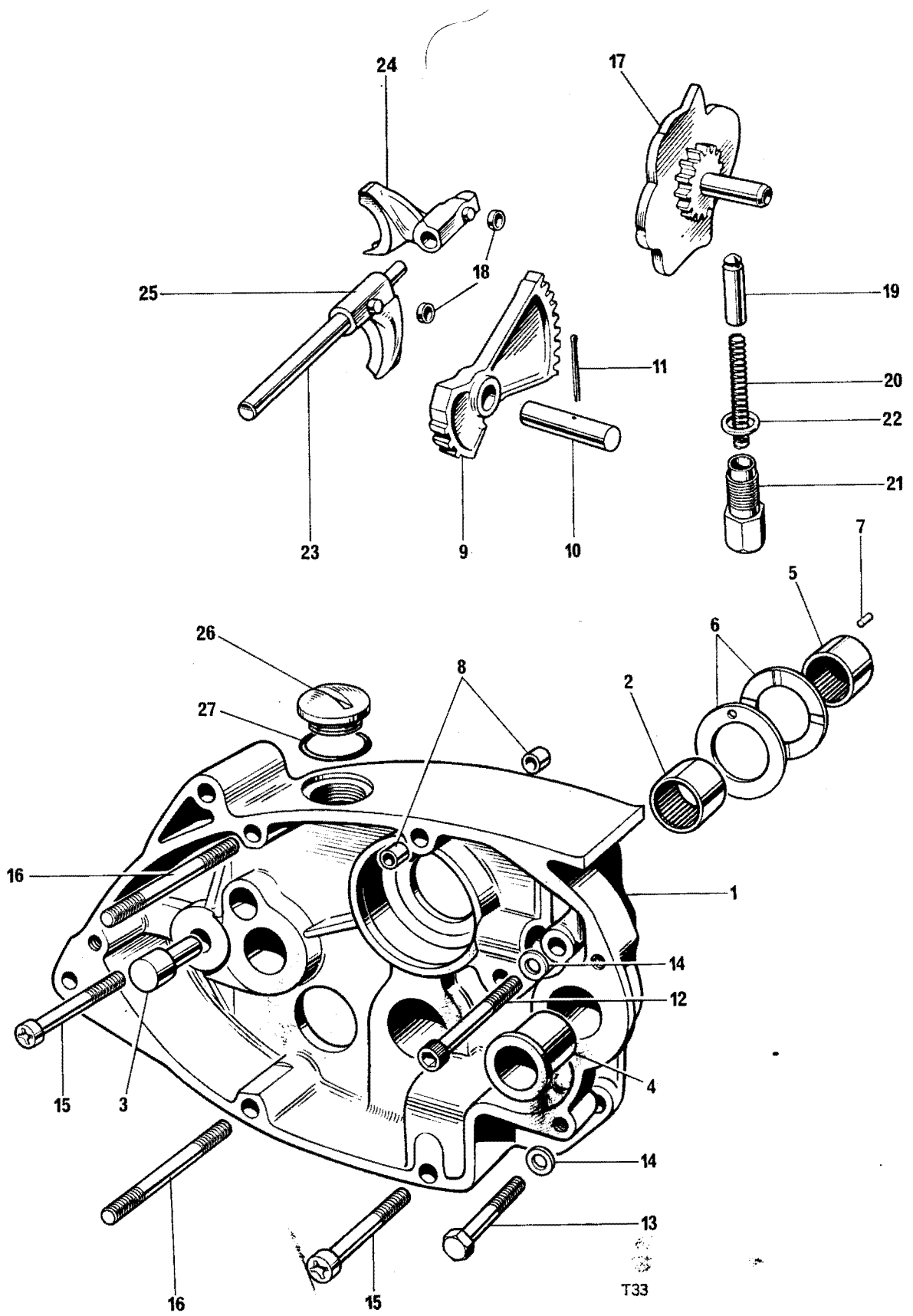

Fig. 9. GEARBOX INNER COVER AND SELECTORS



## GEARBOX INNER COVER AND SELECTORS

REF. NO.	PART NO.	DESCRIPTION	QUANTITY	REMARKS
1	T2137	INNER COVER	1	
2	T1614	Layshaft bearing	1	
3	T3727	Kickstart stop	1	
4	T412	Bush (F/C spindle)	1	
5	T1606	Layshaft, needle roller bearing	1	
6	T1607	Thrust washer	2	
7	T912	Peg, L/S thrust washer	1	(Also in crankcase group)
8	T989	Dowel, inner to outer cover	2	
9	T397	Quadrant	1	
10	T1896	Quadrant spindle	1	
11	D1928	Split pin, $\frac{5}{8}$ in. x $1\frac{3}{8}$ in.	1	
12	14-7101	Socket screw ( $3\frac{1}{4}$ in. U.H.)	1	
13	14-6121	Bolt, inner cover to crankcase ( $2\frac{1}{4}$ in. U.H.)	1	
14	E3446	Washer, inner cover to crankcase	2	
15	14-6614	Screw inner cover to crankcase ( $2\frac{1}{2}$ in. U.H.)	2	
16	14-1431	Stud, gearbox cover	2	
17	T3650	Camplate	1	
18	NT261	Camplate roller	2	
19	T44	Plunger	1	
20	T3661	Plunger spring	1	
21	T2172	Plunger sleeve nut	1	
22	T3978	Washer	1	
23	T291	Selector spindle	1	
24	T260B	Selector fork mainshaft	1	
25	T913	Selector fork layshaft	1	
26	T2166	Filler cap	1	
27	E8782	"O" ring	1	

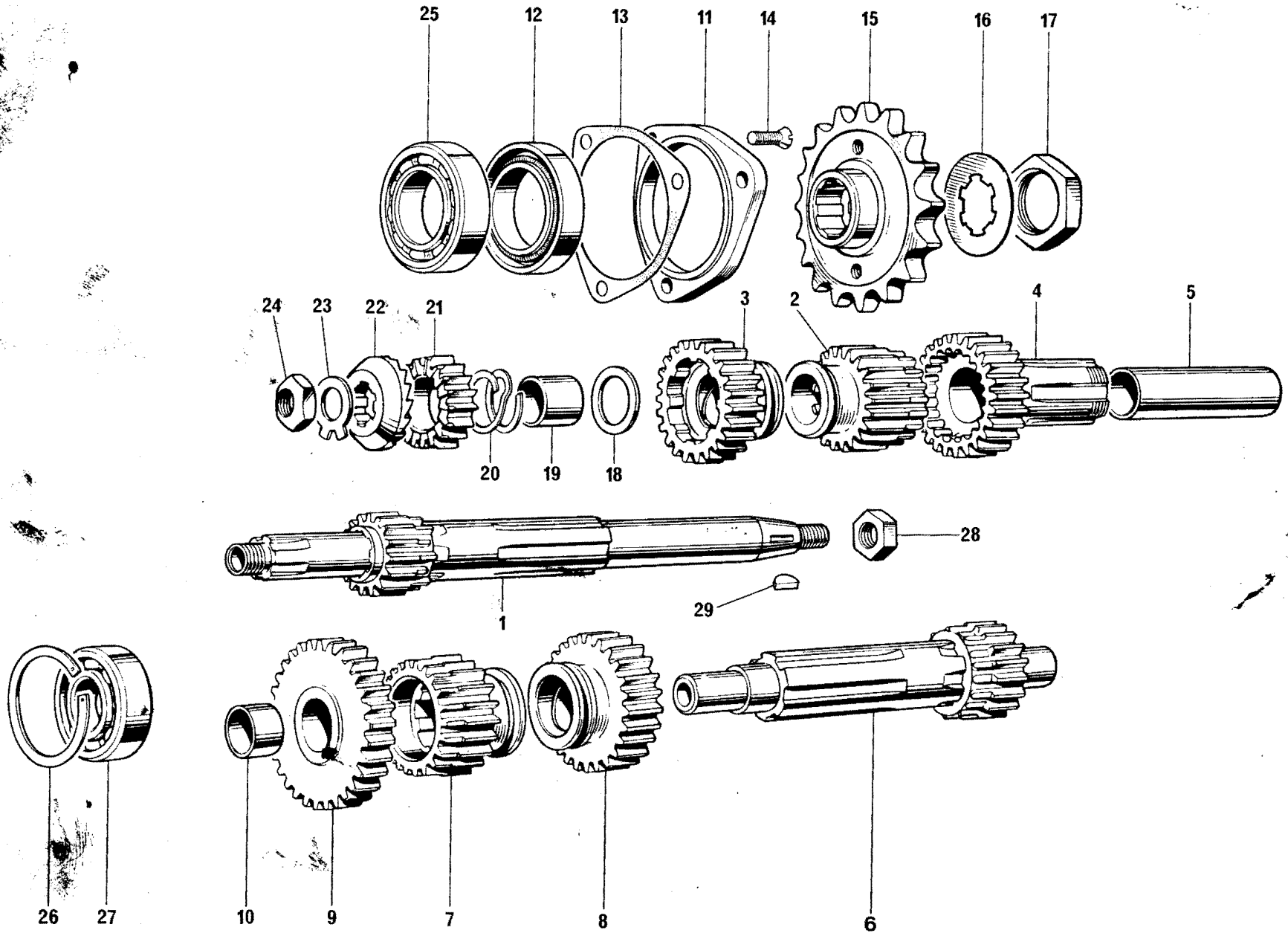

Fig. 10. GEARBOX SHAFTS AND GEARS

## GEARBOX SHAFTS AND GEARS

1	T2174	MAINSHAFT C/W LOW GEAR	...	...	...	...	...	...	1
2	T3857	MAINSHAFT 2ND GEAR	...	...	...	...	...	...	1
3	T3858	MAINSHAFT 3RD GEAR	...	...	...	...	...	...	1
4	T2176	MAINSHAFT HIGH GEAR	...	...	...	...	...	...	1
5	T3785	High gear bush	...	...	...	...	...	...	1
6	T3864	LAYSHAFT C/W HIGH GEAR	...	...	...	...	...	...	1
7	T3860	LAYSHAFT 3RD GEAR	...	...	...	...	...	...	1
8	T3861	LAYSHAFT 2ND GEAR	...	...	...	...	...	...	1
9	T3862	LAYSHAFT LOW GEAR	...	...	...	...	...	...	1
10	T928	Low gear bush	...	...	...	...	...	...	1
11	T2153	Housing, high gear oil seal	...	...	...	...	...	...	1
12	T3634	Oil seal high gear	...	...	...	...	...	...	1
13	T2165	Gasket, high gear oil seal housing	...	...	...	...	...	...	1
14	14-6610	Fixing screw ( $\frac{3}{8}$ in. U.H.)	...	...	...	...	...	...	3
15	T1918	Gearbox sprocket 19T	...	...	...	...	...	...	1
16	T2116	Tab washer	...	...	...	...	...	...	1
17	S542	Locknut sprocket	...	...	...	...	...	...	1
18	T1962	Kickstart pinion washer	...	...	...	...	...	...	1
19	T1963	Kickstart pinion sleeve	...	...	...	...	...	...	1
20	T1250	Kickstart pinion spring	...	...	...	...	...	...	1
21	T2170	Kickstart pinion	...	...	...	...	...	...	1
22	T731	Kickstart ratchet	...	...	...	...	...	...	1
23	T732	Tab washer mainshaft nut	...	...	...	...	...	...	1
24	S594	Nut, mainshaft	...	...	...	...	...	...	1
25	T448	High gear bearing	...	...	...	...	...	...	1
26	T280	Bearing circlip	...	...	...	...	...	...	1
27	T3621	Mainshaft bearing	...	...	...	...	...	...	1
28	S681	Nut, clutch hub to mainshaft	...	...	...	...	...	...	1
29	S66-1	Key	...	...	...	...	...	...	1

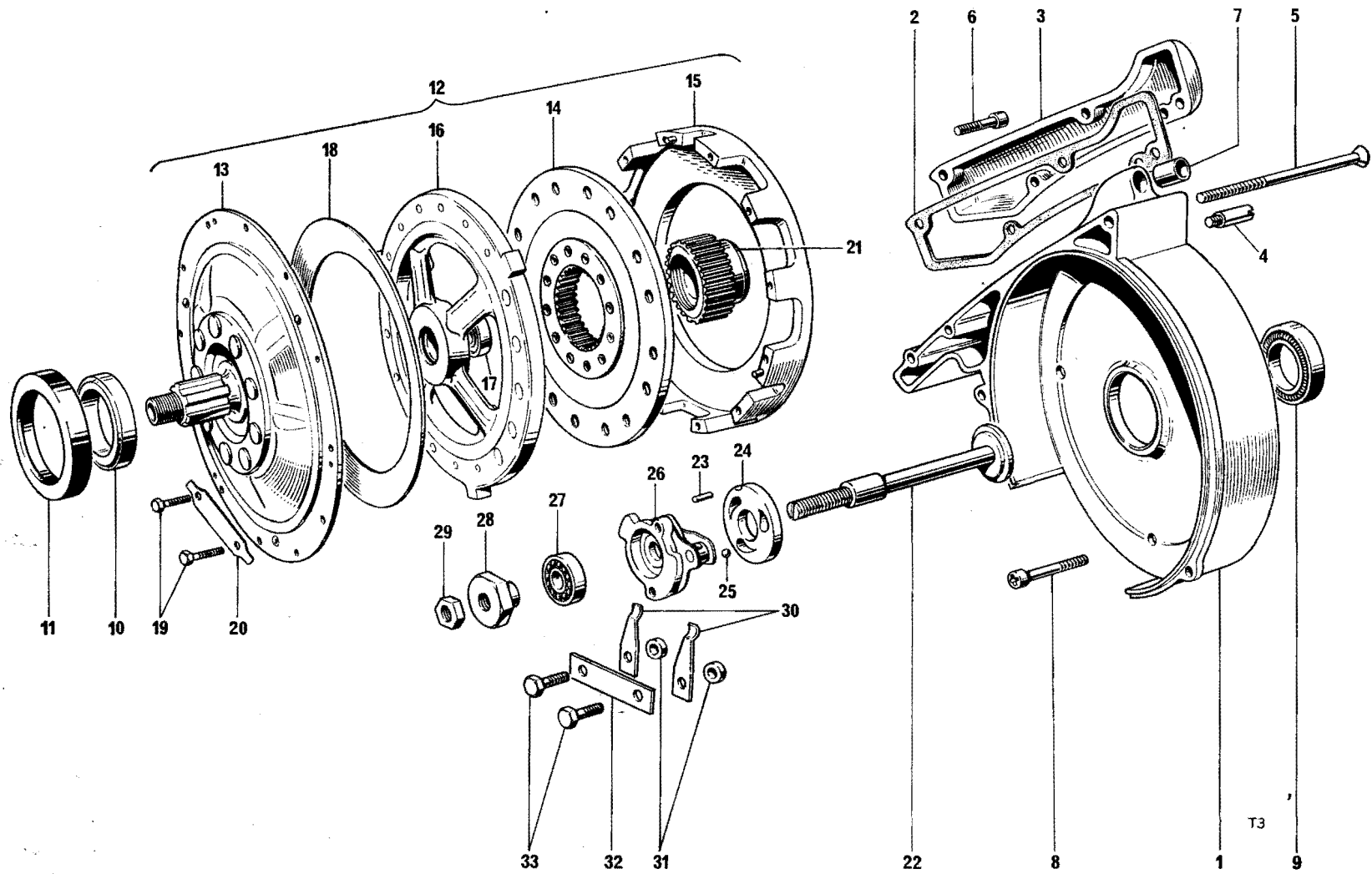

Fig. 11. CLUTCH AND CLUTCH OPERATING MECHANISM

## CLUTCH AND CLUTCH OPERATING MECHANISM

1	T2554	Clutch cover	...	...	...	...	...	...	1
2	T2556	Joint washer	...	...	...	...	...	...	1
3	T2555	Cover, breather duct	...	...	...	...	...	...	1
4	T3756	Adaptor	...	...	...	...	...	...	1
5	14-6510	Screw, long, cover to crankcase (4 in. U.H.)	...	...	...	...	...	...	1
6	S680	Screw short cover to crankcase ( $\frac{1}{8}$ in.)	...	...	...	...	...	...	3
7	T2557	Tube	...	...	...	...	...	...	1
8	14-6610	Screw cover to crankcase ( $1\frac{1}{2}$ in.)	...	...	...	...	...	...	3
9	T3642	Oil seal cover to mainshaft	...	...	...	...	...	...	1
10	T2479	Sleeve, shaft oil seal	...	...	...	...	...	...	1
11	T3642	Oil seal clutch shaft	...	...	...	...	...	...	1
12	T2562	CLUTCH ASSEMBLY (BORG & BECK 76183)	...	...	...	...	...	...	1
13	T3705	End cover, assembly (BORG & BECK 76169)	...	...	...	...	...	...	1
14	T3709	Driven plate assembly (BORG & BECK 53273)	...	...	...	...	...	...	1
15	T3708	Drive ring (BORG & BECK 76167)	...	...	...	...	...	...	1
16	T3715	Pressure plate (BORG & BECK 76184)	...	...	...	...	...	...	1
17	T3717	Thrust bearing (BORG & BECK 76168)	...	...	...	...	...	...	1
18	T3718	Diaphragm spring red (BORG & BECK 75303/13)	...	...	...	...	...	...	1
19	T3719	Bolt end cover to housing (BORG & BECK K26904)	...	...	...	...	...	...	12
20	T3720	Tab washer, end cover to housing (BORG & BECK 76170)	...	...	...	...	...	...	6
21	T2580	Clutch hub	...	...	...	...	...	...	1
22	T2552	Pull rod clutch release	...	...	...	...	...	...	1
23	T3640	Peg, outer chaincase (for clutch operation)	...	...	...	...	...	...	1
24	T2465	Thrust plate inner	...	...	...	...	...	...	1
25	S70-3	Ball, $\frac{1}{4}$ in. dia.	...	...	...	...	...	...	3
26	T2547	Clutch lever complete	...	...	...	...	...	...	1
27	T3647	Bearing, outer thrust plate	...	...	...	...	...	...	1
28	T2553	Sleeve nut	...	...	...	...	...	...	1
29	14-0402	Locknut	...	...	...	...	...	...	1
30	T2473	Spring, outer thrust plate	...	...	...	...	...	...	2
31	T3638	Distance piece, outer thrust plate	...	...	...	...	...	...	2
32	T2474	Tab washer	...	...	...	...	...	...	1
33	14-6102	Bolt ( $\frac{1}{4}$ in. U.H.)	...	...	...	...	...	...	2

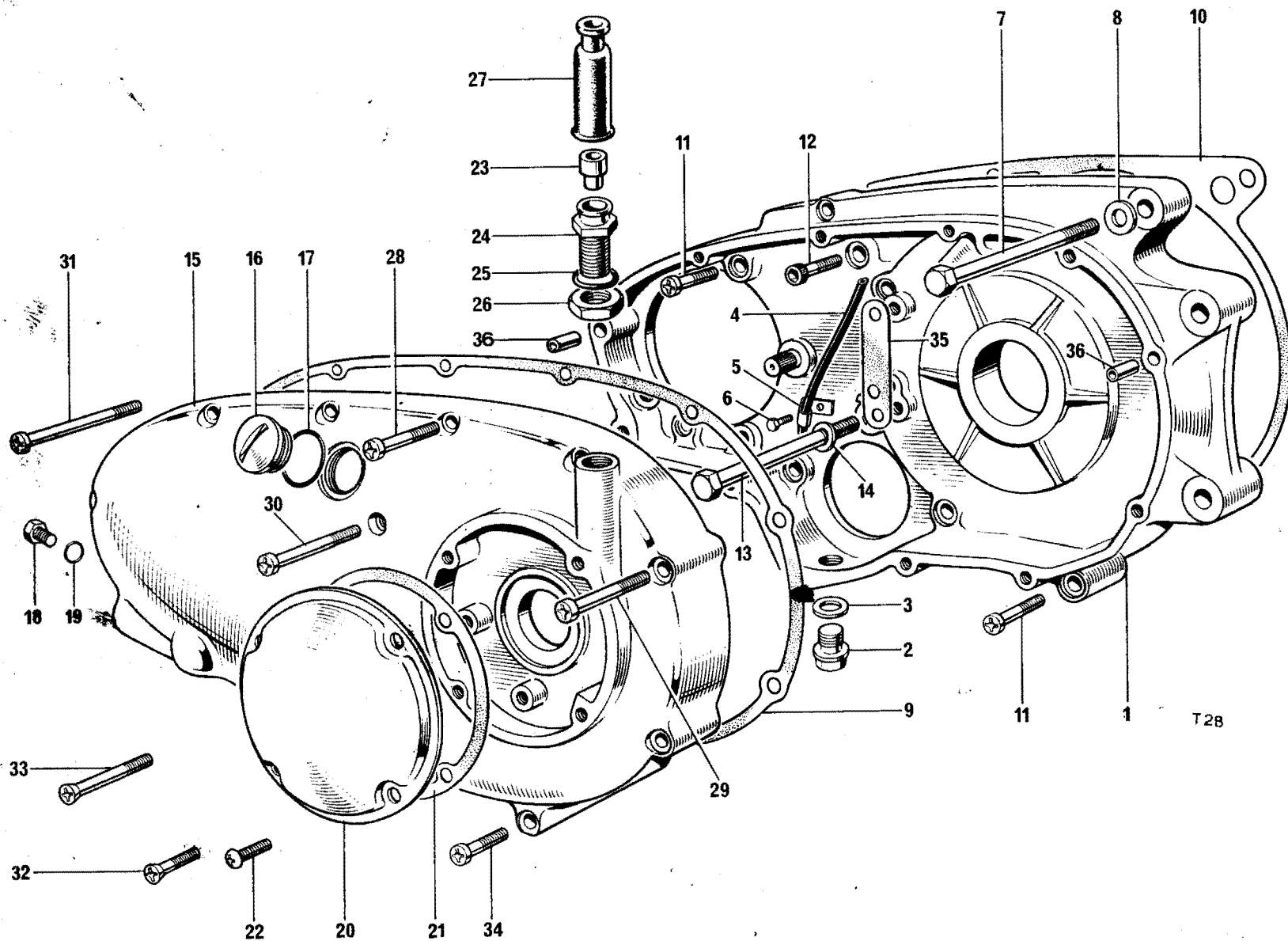

Fig. 12. INNER AND OUTER CHAINCASE

## INNER AND OUTER CHAINCASE

Ref. No.	Part No.	Description	Quantity	Remarks
1	T2460	Inner primary chaincase	1	
2	S536	Drain plug	1	
3	E402	Washer	1	
4	E8786	Tube, chain oiler	1	
5	E4705	Clip, chain oiler—tube	1	
6	14-6101	Bolt, clip ( $\frac{1}{2}$ in. U.H.)	1	
7	S1819	Bolt, long ( $4\frac{1}{2}$ in. U.H.)	1	
8	S25-3	Washer	1	
9	T2581	Joint washer inner to outer chaincase	1	
10	T2558	Gasket inner case to chaincase	1	
11	14-6606	Screw, short (1 in. U.H.)	2	
12	14-7006	Socket screw (1 in. U.H.)	7	
13	S1820	Bolt ( $4\frac{1}{2}$ in. U.H.)	1	
14	S25-3	Washer	1	
15	T3953	Outer primary chaincase	1	
16	T2166	Filler plug	1	
17	E8782	"O" ring	1	
18	T3619	Tensioner adjuster plug	1	
19	T3620	"O" ring	1	
20	T3954	Inspection cover	1	
21	T3955	Inspection cover gasket	1	
22	14-6605	Screw, inspection cover ( $\frac{3}{8}$ in. U.H.)	4	
23	T2220	Clutch cable abutment	1	
24	T1646	Adaptor	1	
25	T3955	Sealing Ring	1	
26	S567	Locknut	1	
27	T1646	Rubber cap	1	
28	14-6611	Screw, outer to inner chaincase ( $1\frac{3}{4}$ in. U.H.)	7	
29	14-6612	Screw, outer to inner chaincase (2 in. U.H.)	1	
30	14-6613	Screw, long outer to inner chaincase ( $2\frac{1}{2}$ in.)	2	
31	14-6615	Screw, outer to inner chaincase (3 in. U.H.)	1	
32	14-6504	Screw, short countersunk ( $\frac{3}{4}$ in. U.H.)	2	
33	14-6510	Screw, longer countersunk (2 in. U.H.)	1	
34	14-6610	Screw, short, chaincase ( $1\frac{1}{2}$ in. U.H.)	1	
35	T2581	Joint washer	1	
36	T989	Dowel	2	

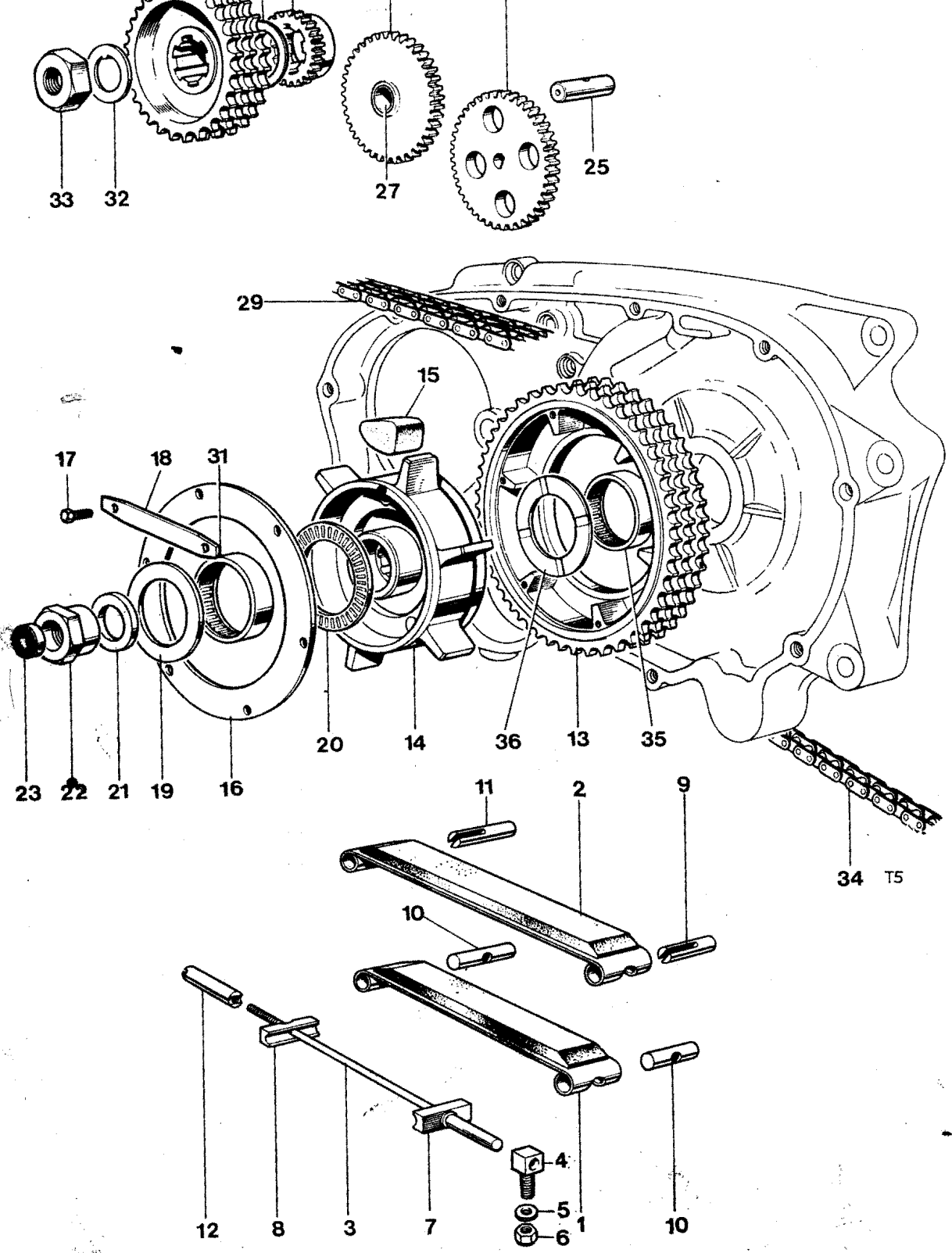

Fig. 13. PRIMARY TRANSMISSION AND OIL PUMP DRIVE



## PRIMARY TRANSMISSION AND OIL PUMP DRIVE

1	T3610	Tensioner blade	...	...	...	...	...	...	...	1
2	E6061	Tensioner blade	...	...	...	...	...	...	...	1
3	T3983	Tie rod	...	...	...	...	...	...	...	1
4	T3986	Eye bolt	...	...	...	...	...	...	...	1
5	T3987	Washer	...	...	...	...	...	...	...	1
6	14-1901	Nut	...	...	...	...	...	...	...	1
7	E9257	Saddle washer (rear)	...	...	...	...	...	...	...	1
8	E9258	Saddle washer (adjuster end)	...	...	...	...	...	...	...	1
9	E9256	Trunnion	...	...	...	...	...	...	...	1
10	E5977	Trunnion	...	...	...	...	...	...	...	2
11	T3614	Pivot pin...	...	...	...	...	...	...	...	1
12	T3617	Adjuster nut	...	...	...	...	...	...	...	1
13	T2245	Clutch sprocket	...	...	...	...	...	...	...	1
14	T2471	Spider	...	...	...	...	...	...	...	1
15	T1723	Shock absorber rubber	...	...	...	...	...	...	...	1
16	T4004	Retaining plate	...	...	...	...	...	...	...	1
17	T3940	Bolt, retaining plate	...	...	...	...	...	...	...	6
18	T3941	Tab washer	...	...	...	...	...	...	...	3
19	T2215	Outer thrust washer, clutch shaft	...	...	...	...	...	...	...	1
20	T3646	Thrust race	...	...	...	...	...	...	...	1
21	T2478	Spacer, shock absorber nut	...	...	...	...	...	...	...	1
22	T2480	Nut	...	...	...	...	...	...	...	1
23	T3644	Oil seal	...	...	...	...	...	...	...	1
24	E7248	Driven gear	...	...	...	...	...	...	...	1
25	E6881	Spindle, intermediate gear	...	...	...	...	...	...	...	1
26	E7246	INTERMEDIATE GEAR C/W BUSH	...	...	...	...	...	...	...	1
27	E6885	Bush	...	...	...	...	...	...	...	1
28	E7249	Oil pump driving gear	...	...	...	...	...	...	...	1
29	D699	Primary chain, triple row, 82 links	...	...	...	...	...	...	...	1
30	E6890	Engine sprocket	...	...	...	...	...	...	...	1
31	E9634	Shim, engine sprocket (0-010 in. thick)	...	...	...	...	...	...	...	as required
32	E8785	Tab washer	...	...	...	...	...	...	...	1
33	S585	Nut, engine sprocket	...	...	...	...	...	...	...	1
34	D2118	Rear chain 107 links	...	...	...	...	...	...	...	1
35	T3643	Needle race	...	...	...	...	...	...	...	2
36	T2214	Thrust washer, inner	...	...	...	...	...	...	...	1

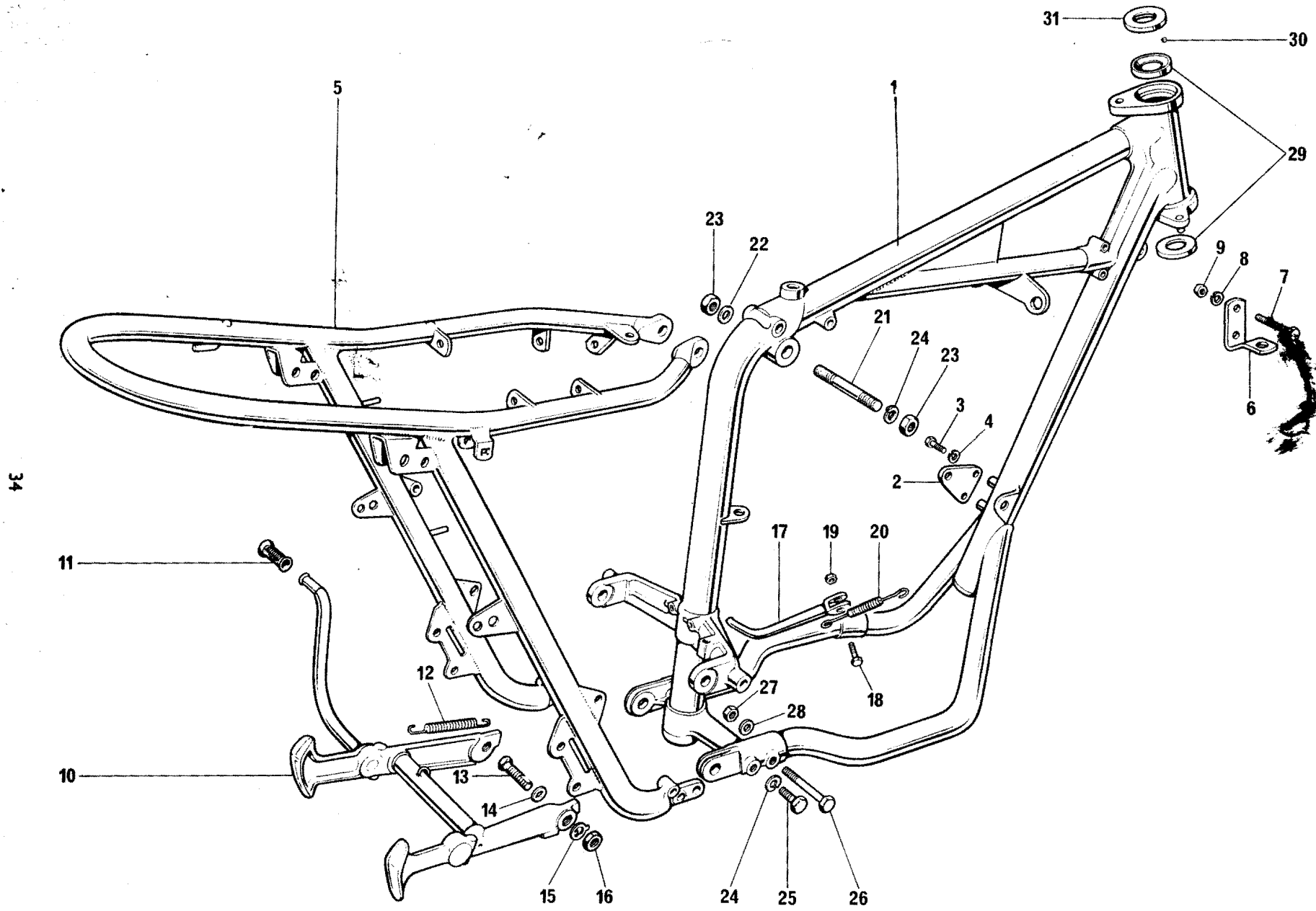

Fig. 14. FRAME

## FRAME

Ref. No.	Part No.	Description	Quantity	Remarks
1	F9329	Front Frame ... ..	1	
Not illus.	F7155	Lock stops ... ..	1	
2	F7159	Front D.S. engine plate ... ..	1	
3	14-0126	Bolt ( $\frac{3}{8}$ in. U.H.) ... ..	2	
4	S26-1	Spring washer ... ..	2	
5	F9330	Rear frame ... ..	1	
6	F9380	Mounting bracket, petrol tank ... ..	2	
7	S1805	Bolt ( $2\frac{1}{8}$ in. U.H.) ... ..	2	
8	S26-3	Washer ... ..	2	
9	14-0402	Nut ... ..	2	
10	F11267	Centre stand ... ..	1	
11	T2331	Pedal rubber ... ..	1	
12	F4671	Spring ... ..	1	
13	S1978	Pivot bolt ... ..	2	
14	F5679	Washer ... ..	2	
15	F11270	Tab washer ... ..	2	
16	14-0404	Nut ... ..	2	
17	F7849	Prop stand ... ..	1	
18	F7021	Swivel pin ... ..	1	
19	14-0703	Nut, swivel pin ... ..	1	
20	F8392	Spring ... ..	1	
21	S1801	Stud, top rear to front frame ( $3\frac{7}{8}$ in.) ... ..	1	
22	S26-1	Washer, frame ... ..	2	
23	14-0303	Nut ... ..	2	
24	99-0046	Spring Washer ... ..	4	
25	S588	Bolt, bottom rear to front frame ( $1\frac{3}{16}$ in. U.H.) ... ..	2	
26	14-0251	Bolt, front rear to front frame ( $1\frac{1}{4}$ in.) ... ..	2	
27	14-0304	Nut ... ..	2	
28	F4370	Washer ... ..	2	
29	H111	Cup, top and bottom steering race ... ..	2	
30	S70-3	Ball, top and bottom ... ..	40	
31	H1018	Top cone (c/w dust cover) ... ..	1	

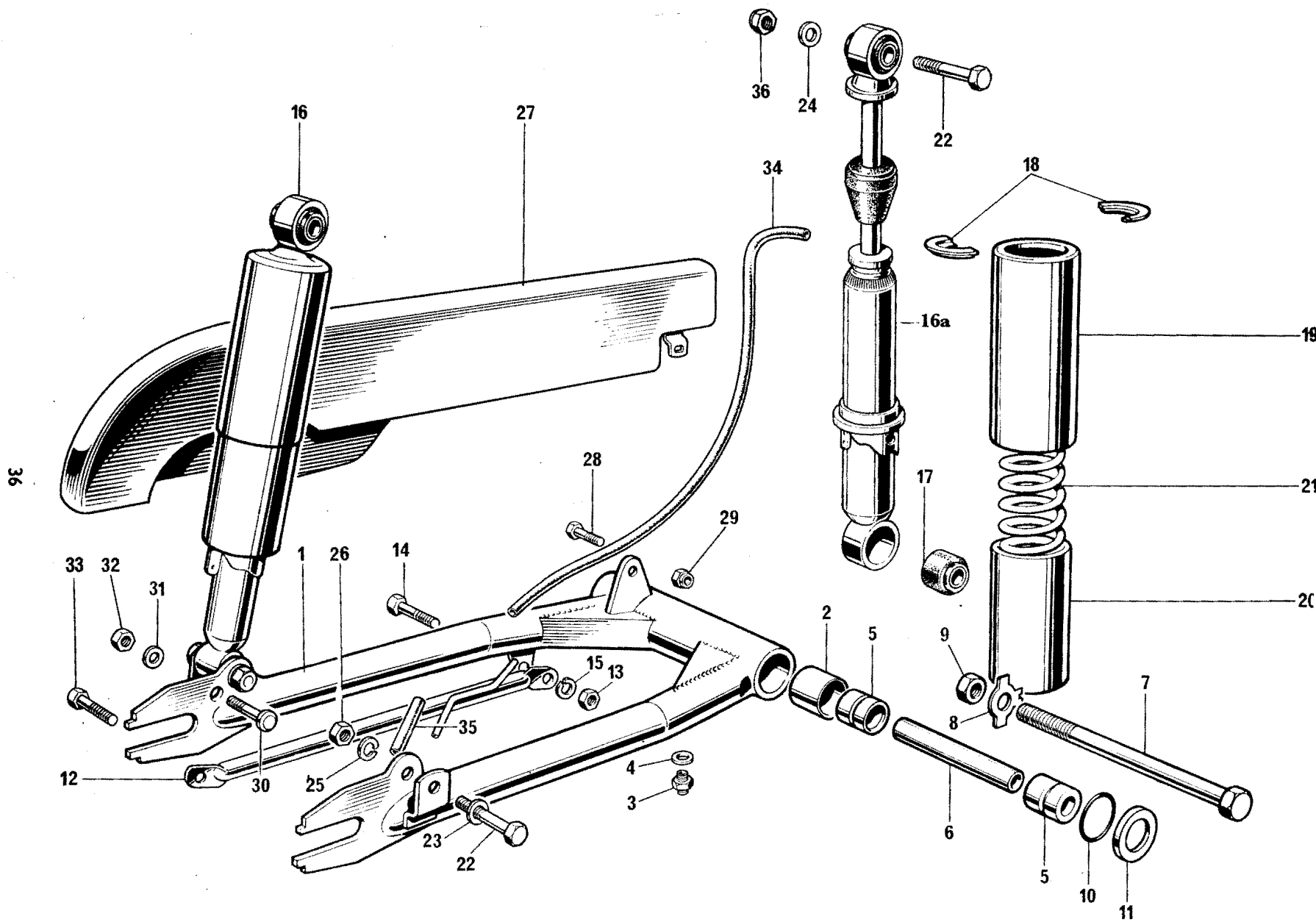

Fig. 15. SWINGING FORK AND SUSPENSION UNITS

## SWINGING FORK AND SUSPENSION UNITS

Ref. No.	Part No.	DESCRIPTION	QUANTITY	REMARKS
1	F10045	SWINGING FORK	1	
2	F6042	Bush	2	
3	NW100	Grease nipple	1	
4	WE170	Fibre washer	1	
5	F6821	Bobbin	2	
6	F5313	Distance tube	1	
7	S620	S/arm bolt	1	
8	F5944	Tab washer	1	
9	S545	Nut	1	
10	F8090	"O" ring	2	
11	F7848	Oil seal housing	2	
12	F7365	Torque stay	1	
13	14-0304	Nut	1	
14	S1802	Bolt ( $\frac{3}{8}$ in.)	1	
15	99-0046	Spring washer	1	
16	64052089	SUSPENSION UNIT (SB4 x 133)	2	
16a	Ref. only	Damper unit only 64052090	2	
17	99-0122	Bonded bush 64533645	4	
18	99-0107	Spring retainer 9054/171	4	
19	99-0106	Outer dirt shield 9045/151	2	
20	99-0103	Inner dirt shield 9054/47	2	
21	64532786	Spring (110 lbs.)	2	
22	14-0235	Bolt, top and bottom (2 in. U.H.)	4	
23	S25-3	Washer, bottom bolt	2	
24	GS308	Washer, top bolt	2	
25	S26-1	Spring washer, bottom bolt	2	
26	14-0303	Nut	2	
27	F9383	Rear chainguard	1	
28	14-0113	Front pivot bolt ( $\frac{5}{8}$ in. U.H.)	1	
29	14-0702	Self-locking nut	1	
30	F9387	Bolt, rear chainguard to fork ( $\frac{3}{8}$ in.)	1	
31	S26-3	Washer	1	
32	14-0302	Nut	1	
33	14-6131	Bolt ( $\frac{3}{4}$ in. U.H.)	1	
34	F7532	Long chain oiler pipe	1	
35	F9997	Short chain oiler pipe	1	
36	14-1303	Nut	2	

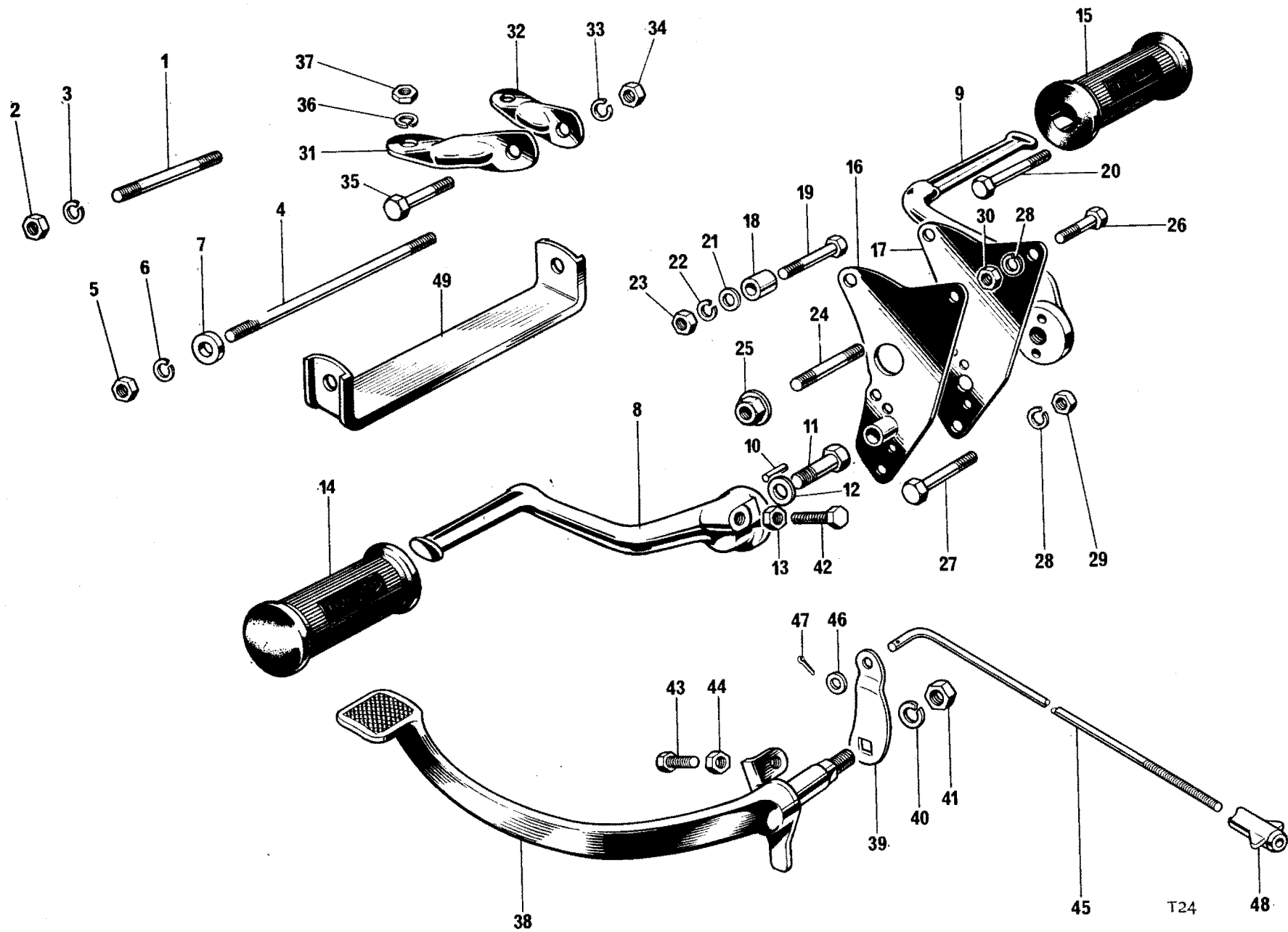

Fig. 16. ENGINE UNIT FITTINGS AND FOOTRESTS

## ENGINE UNIT FITTINGS AND FOOTRESTS

1	S571	Stud, front engine to frame ( $3\frac{7}{8}$ in. O.A.)	...	...	...	...	1
2	14-0804	Nut, stud	...	...	...	...	2
3	99-0046	Spring washer	...	...	...	...	2
4	S572	Stud (bottom) engine to frame ( $10\frac{1}{2}$ in. O.A.)	...	...	...	...	1
5	14-0304	Nut, stud	...	...	...	...	2
6	99-0046	Spring washer	...	...	...	...	2
7	F5532	Spacer, bottom engine fixing	...	...	...	...	1
8	F9623	Drive side footrest	...	...	...	...	1
9	F9624	Timing side footrest	...	...	...	...	1
10	F5943	Peg	...	...	...	...	4
11	S1969	Bolt, footrest ( $1\frac{1}{8}$ in. U.H.)	...	...	...	...	2
12	F8243	Washer, footrest stud	...	...	...	...	2
13	14-0401	Locknut	...	...	...	...	1
14	F9279	Footrest rubber T.S.	...	...	...	...	1
15	F9630	Footrest rubber D.S.	...	...	...	...	1
16	F9627	Rear engine plate T.S.	...	...	...	...	1
17	F9629	Rear engine plate D.S.	...	...	...	...	1
18	F7157	Spacer D.S. rear engine plate	...	...	...	...	2
19	14-0222	Bolt, D.S. rear engine plate to engine ( $2\frac{1}{4}$ in. U.H.)	...	...	...	...	2
20	14-0221	Bolt, T.S. rear engine plate to engine (2 in. U.H.)	...	...	...	...	2
21	S25-3	Washer, rear engine plate to engine	...	...	...	...	4
22	S26-3	Spring washer	...	...	...	...	4
23	14-1302	Nut	...	...	...	...	4
24	S548	Stud, D.S. and T.S. pivot lug to engine plate ( $1\frac{3}{8}$ in. O.A.)	...	...	...	...	2
25	F7389	Nut stud	...	...	...	...	2
26	14-0126	Bolt, upper rear engine plate to frame ( $\frac{3}{8}$ in. U.H.)	...	...	...	...	2
27	14-0234	Bolt, lower rear engine plate to frame ( $1\frac{3}{4}$ in. U.H.)	...	...	...	...	2
28	S26-1	Spring washer	...	...	...	...	4
29	14-1303	Nut	...	...	...	...	2
30	14-0403	Nut	...	...	...	...	2
31	F9379	Torque stay engine R.H.	...	...	...	...	1
32	F9378	Torque stay engine L.H.	...	...	...	...	1
33	S26-1	Spring washer	...	...	...	...	2
34	14-0303	Nut	...	...	...	...	2
35	14-0236	Bolt, torque stay to frame ( $2\frac{1}{4}$ in. U.H.)	...	...	...	...	1
36	S26-3	Spring washer	...	...	...	...	1
37	14-0302	Nut	...	...	...	...	1
38	F9635	Rear brake pedal	...	...	...	...	1
39	F6064	Lever	...	...	...	...	1
40	S26-1	Spring washer	...	...	...	...	1
41	14-0303	Nut	...	...	...	...	1
42	14-0106	Stop bolt (1 in. U.H.)	...	...	...	...	1
43	14-0103	Adjuster, stoplamp switch ( $\frac{3}{8}$ in. U.H.)	...	...	...	...	1
44	14-0401	Nut, adjuster	...	...	...	...	1
45	F7386	Brake rod	...	...	...	...	1
46	S25-13	Washer	...	...	...	...	1
47	D2683	Split pin, $\frac{1}{8}$ in. x $\frac{3}{8}$ in.	...	...	...	...	1
48	F7387	Adjuster nut	...	...	...	...	1
49	F9529	Oil pipe retaining strap	...	...	...	...	1

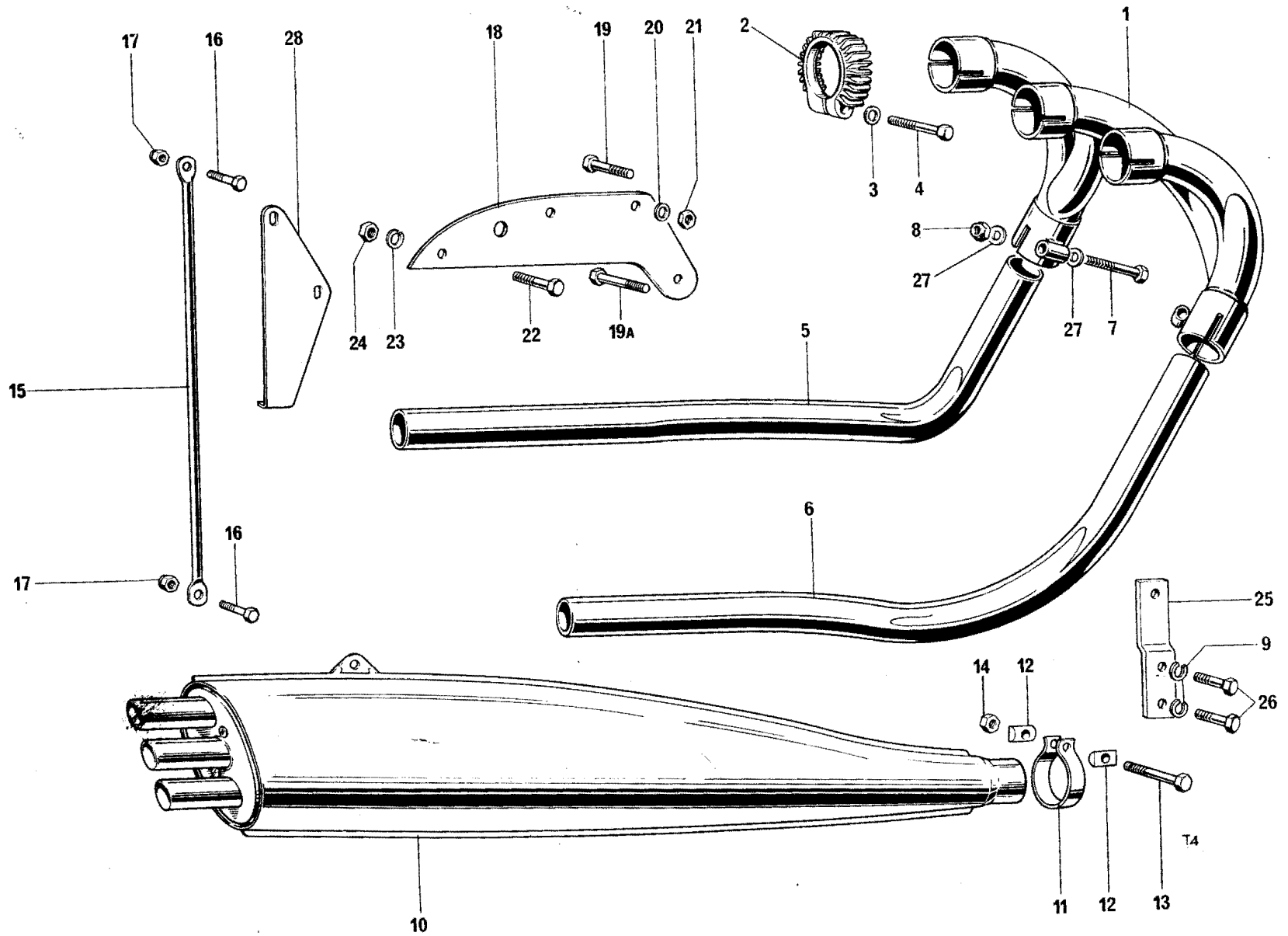

Fig. 17. EXHAUST PIPES AND SILENCERS



## EXHAUST PIPES AND MANIFOLDS

1	E7597	Exhaust manifold	...	...	...	...	...	...	...	1	
2	E6743	Finned clip	...	...	...	...	...	...	...	3	
3	E410A	Hemispherical washer	...	...	...	...	...	...	...	3	
4	E6744	Bolt (1 $\frac{3}{8}$ in. U.H.)	...	...	...	...	...	...	...	3	
5	E9463	Exhaust pipe D.S.	...	...	...	...	...	...	...	1	
6	E9464	Exhaust pipe T.S.	...	...	...	...	...	...	...	1	
7	14-0205	Bolt, exhaust pipe to manifold (1 $\frac{1}{2}$ in. U.H.)	...	...	...	...	...	...	...	2	
8	14-1201	Nut (Cleveloc) exhaust pipe to manifold	...	...	...	...	...	...	...	2	
9	S26-3	Spring washer	...	...	...	...	...	...	...	4	
10	E9036	Silencer D.S.	...	...	...	...	...	...	...	1	
10	E9037	Silencer T.S.	...	...	...	...	...	...	...	1	
11	E7512	Clip	...	...	...	...	...	...	...	2	
12	E3768	'D' washer	...	...	...	...	...	...	...	4	
13	14-0219	Bolt (1 $\frac{1}{2}$ in. U.H.)	...	...	...	...	...	...	...	2	
14	14-1302	Nut, Cleveloc	...	...	...	...	...	...	...	2	
15	F9440	Strut	...	...	...	...	...	...	...	2	
16	14-0101	Screw, strut top and bottom ( $\frac{1}{2}$ in. U.H.)	...	...	...	...	...	...	...	4	
17	14-0301	Nut (Cleveloc)	...	...	...	...	...	...	...	4	
18	E4711	Hanger, frame from silencer T.S. & D.S.	...	...	...	...	...	...	...	2	
19	14-0115	Bolt ( $\frac{7}{8}$ in. U.H.)	...	...	...	...	...	...	...	2	
19a	14-0116	Bolt (1 in. U.H.)	...	...	...	...	...	...	...	2	
20	S25-3	Plain washer	...	...	...	...	...	...	...	2	
21	14-1302	Nut	...	...	...	...	...	...	...	4	
22	14-0114	Bolt, silencer to frame ( $\frac{3}{4}$ in. U.H.)	...	...	...	...	...	...	...	2	
23	S25-3	Spring washer	...	...	...	...	...	...	...	2	
24	14-1302	Nut	...	...	...	...	...	...	...	2	
25	E8902	Bracket D.S. and T.S. silencer	...	...	...	...	...	...	...	2	
26	S1822	Bolt, bracket to silencer ( $\frac{1}{2}$ in. U.H.)	...	...	...	...	...	...	...	4	
27	S25-1	Washer	...	...	...	...	...	...	...	4	
28	F9947	Centre stand stop plate	...	...	...	...	...	...	...		Not illustrated

FORK ASSEMBLY No.1

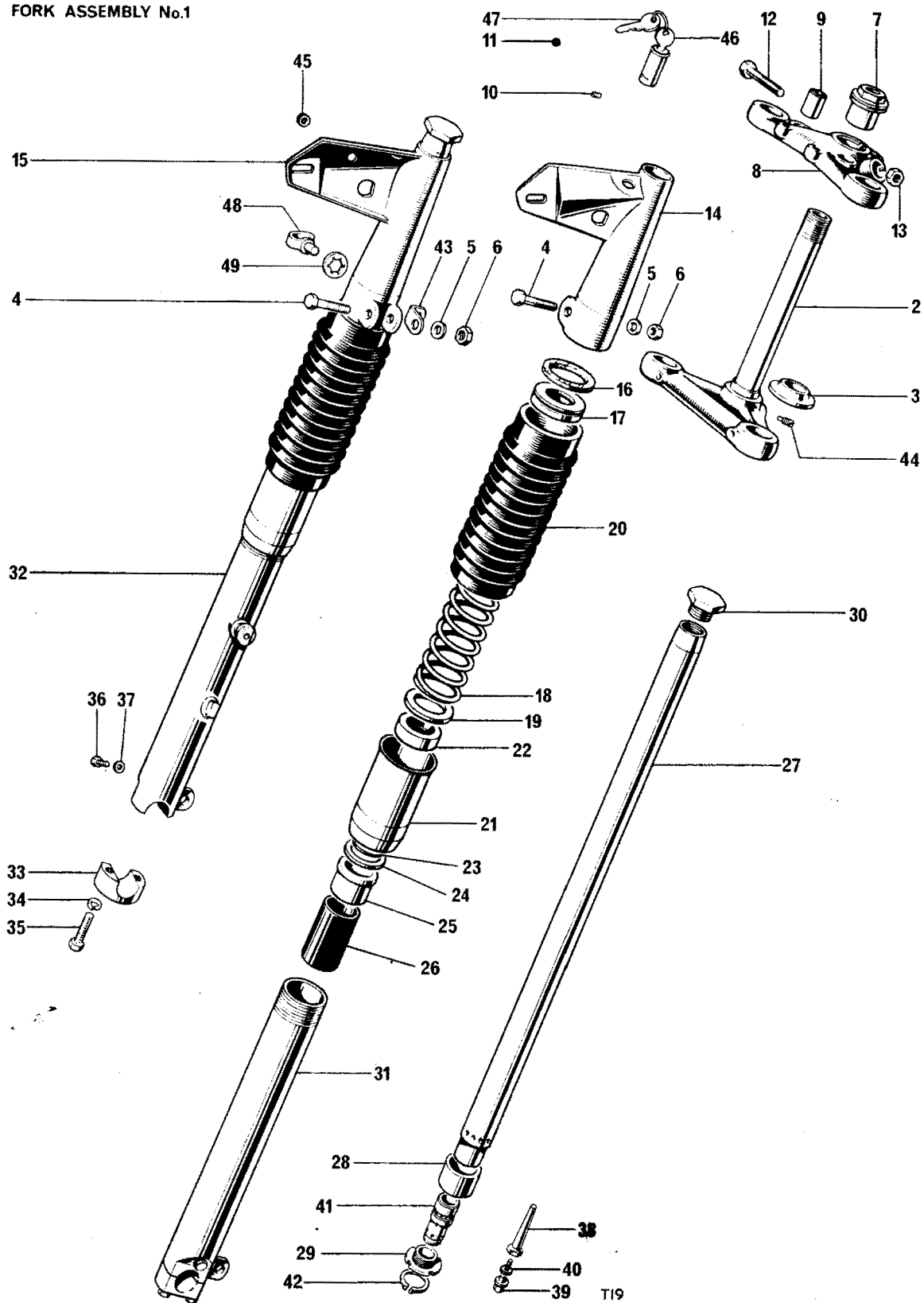

Fig. 18. TELESCOPIC FRONT FORK

**TELESCOPIC FRONT FORK**

1	H2287	FORK ASSEMBLY ... ..	1	
2	H3659	Middle lug and stem ... ..	1	
3	H439	Bottom cone ... ..	1	
4	H2290	Pinch bolt (2¼ in. U.H.) ... ..	2	
5	S25-2	Plain washer ... ..	2	
6	14-1303	Nut ... ..	2	
7	H2108	Fork stem sleeve nut ... ..	1	
8	H2293	Top lug ... ..	1	
9	H1527	Bonded bush ... ..	2	
10	S578	Grub screw ... ..	1	
11	H2266	Sealing plug ... ..	1	
12	S684	Pinch bolt (1¼ in. U.H.)... ..	1	
13	S685	Seated nut ... ..	1	
14	*H3789	Left top cover ... ..	1	
15	†H3790	Right top cover ... ..	1	
16	F4047	Cork washer ... ..	2	
17	H1657	Spring abutment ... ..	2	
18	H1892	Main spring (yellow/green) ... ..	2	
19	H1656	Plain washer ... ..	2	
20	‡H3635	Telescopic gaiter ... ..	2	
21	H3633	DUST EXCLUDER SLEEVE NUT ... ..	2	
22	H1500	Oil seal ... ..	2	
23	H2119	"O" ring ... ..	2	
24	H431	Plain washer ... ..	2	
25	H441	Top bearing ... ..	2	
26	H1896	Damping sleeve ... ..	2	
27	H3878	Stanchion ... ..	2	
28	H443	Lower bearing ... ..	2	
29	H2091	Bearing nut ... ..	2	
30	H2245	Cap nut ... ..	2	
31	H2294	LEFT BOTTOM MEMBER C/W CAP ... ..	1	
32	H2295	RIGHT BOTTOM MEMBER C/W CAP ... ..	1	
33	H1844	Spindle cap ... ..	2	
34	S26-3	Spring washer ... ..	4	
35	14-0218	Cap bolt ... ..	4	
36	H519A	Drain plug ... ..	2	
37	H430	Fibre washer ... ..	2	
38	H2090	Restrictor ... ..	2	
39	H2126	Flanged bolt (¾ in. U.H.) ... ..	2	
40	H1062	Aluminium washer ... ..	2	
41	H2154	Shuttle valve ... ..	2	
42	H2127	Circlip ... ..	2	
43	H3682	Bracket front brake cable ... ..	1	
44	H2107	Locating pin ... ..	1	
45	F6784	Grommet for control cables ... ..	2	
46	F6738	Lock c/w 2 keys ... ..	1	
47	D623	Key (state serial number) ... ..	2	
48	H2270	Cable retainer ... ..	1	
49	F8245	Starlock washer ... ..	1	

Forks with wire clips at gaiters use:—

*H2300	Left top cover ... ..	1
†H2301	Right top cover ... ..	1
‡H1645	Telescopic gaiter ... ..	2
H2083	Gaiter clips ... ..	2

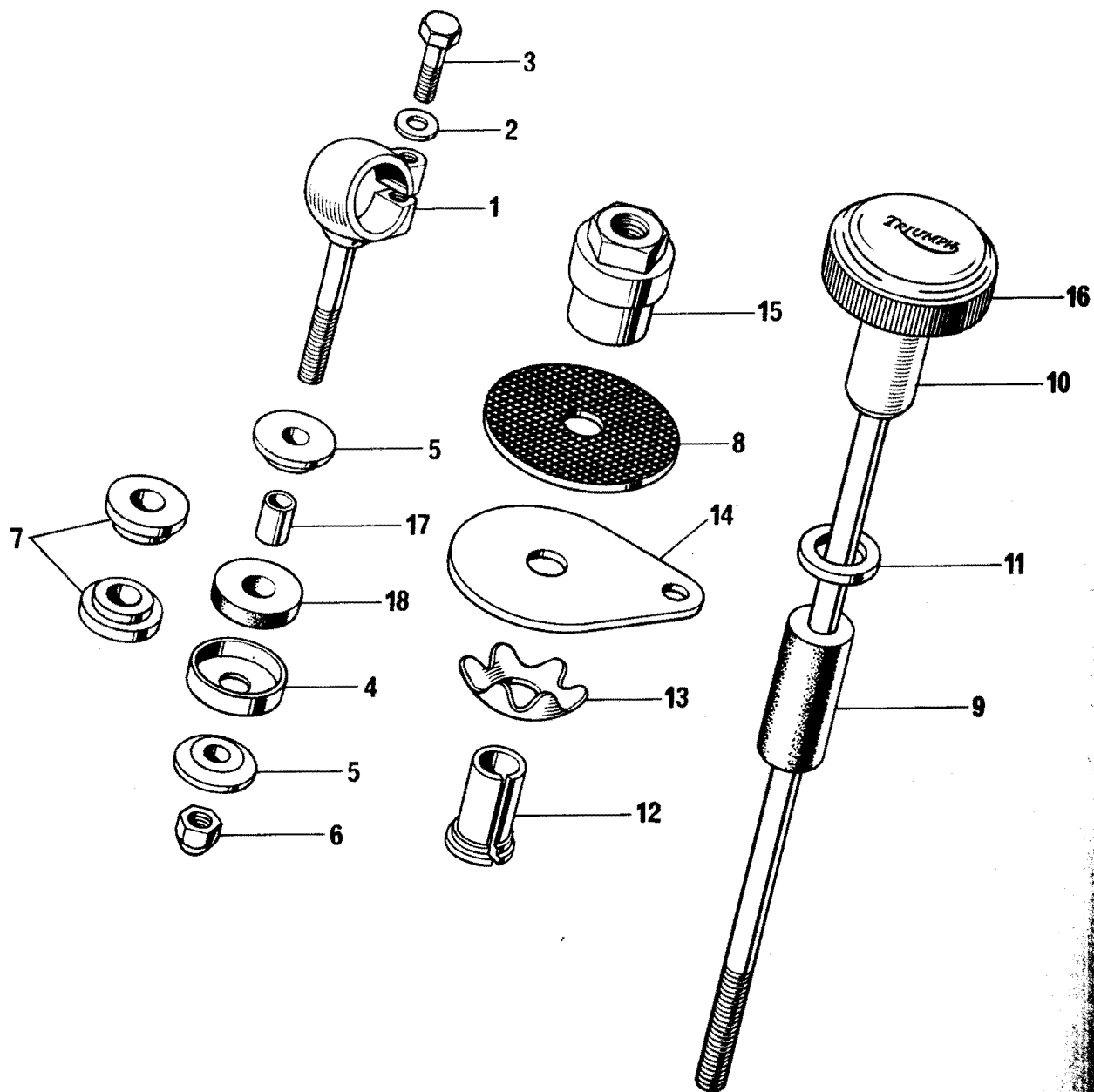

Fig. 19. HANDLEBAR MOUNTINGS AND STEERING DAMPER

### HANDLEBAR MOUNTINGS AND STEERING DAMPER

H2291	Handlebar eyebolt	...	...	...	...	...	...	...	2
F1335	Plain washer	...	...	...	...	...	...	...	2
S589	Bolt (1½ in. U.H.)	...	...	...	...	...	...	...	2
H2221	Cup	...	...	...	...	...	...	...	2
H1529	Hemispherical washer	...	...	...	...	...	...	...	2
14-1903	Self-locking nut	...	...	...	...	...	...	...	2
H1616	Solid bush for handlebar mounted windscreen	...	...	...	...	...	...	...	available
H435	Friction disc	...	...	...	...	...	...	...	1
H1618	Rubber sleeve	...	...	...	...	...	...	...	1
H3602	Steering damper rod c/w knob	...	...	...	...	...	...	...	1
H565	Plain washer	...	...	...	...	...	...	...	1
H3601	Adjuster sleeve	...	...	...	...	...	...	...	1
H95	Spring plate	...	...	...	...	...	...	...	1
H1797	Anchor plate	...	...	...	...	...	...	...	1
H2108	Sleeve nut	...	...	...	...	...	...	...	1
H3604	Nameplate	...	...	...	...	...	...	...	1
H1581	Distance piece	...	...	...	...	...	...	...	2
H1580	Rubber	...	...	...	...	...	...	...	2

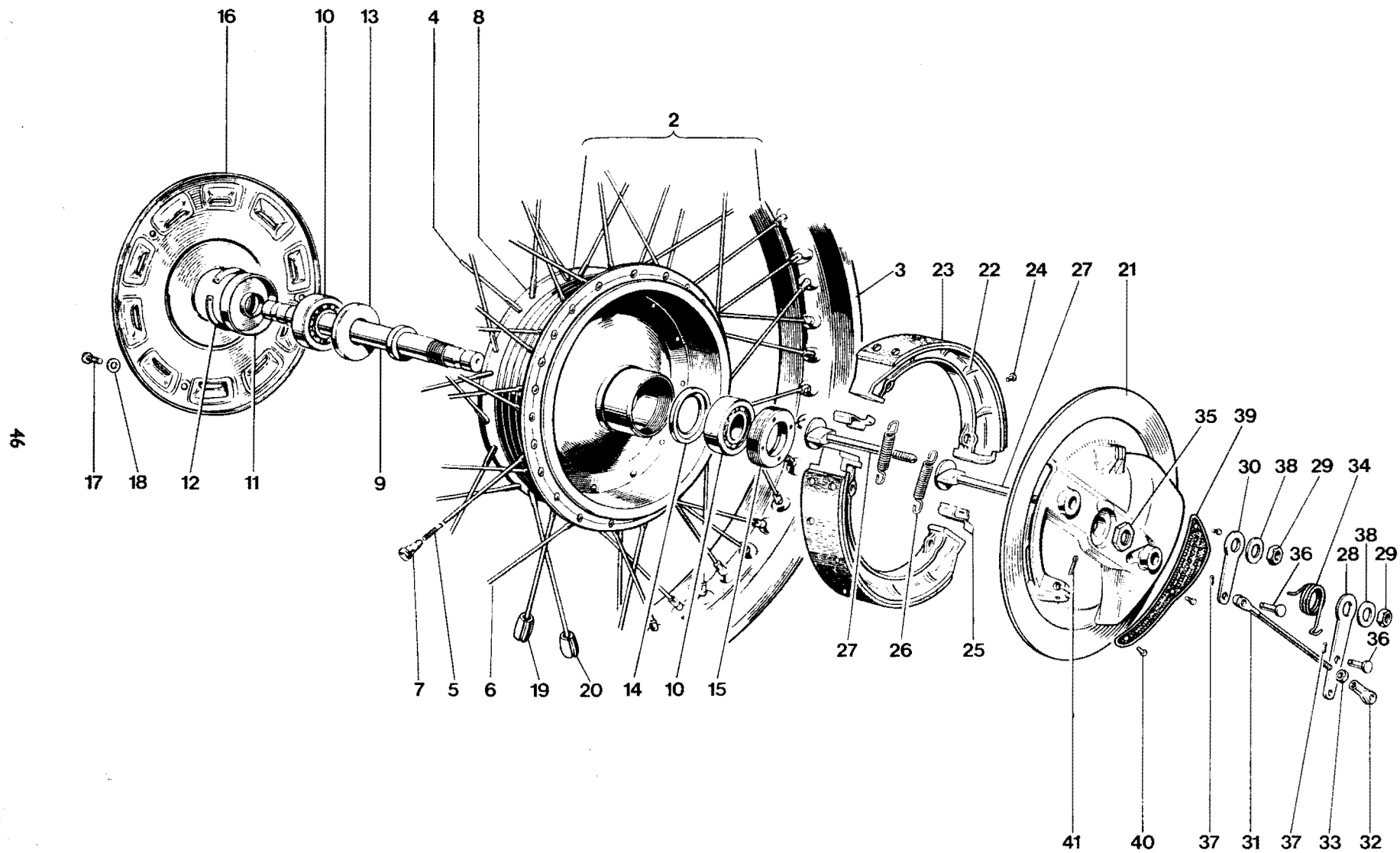

Fig. 20 FRONT WHEEL—EARLIER TYPE

**FRONT WHEEL (EARLIER TYPE)**

W2056	FRONT WHEEL COMPLETE	...	...	...	...	...	1	
W1994	RIM SPOKES AND HUB ASSEMBLY	...	...	...	...	...	1	
W1230	Front wheel rim (WM2-19)	...	...	...	...	...	1	
W1328	Spoke (8/10G x 5 <sup>5</sup> / <sub>8</sub> in.) straight c/w nipple	...	...	...	...	...	20	
W1708	Spoke (8/10G x 4 <sup>2</sup> / <sub>3</sub> <sup>5</sup> / <sub>2</sub> in. 78°) c/w nipple	...	...	...	...	...	10	
W1709	Spoke (8/10G x 4 <sup>7</sup> / <sub>8</sub> in. 100°) c/w nipple	...	...	...	...	...	10	
S79-2	Spoke nipple	...	...	...	...	...	40	
W1995	Hub and brake drum	...	...	...	...	...	1	
W3582	Wheel spindle	...	...	...	...	...	1	
W653	Bearing	...	...	...	...	...	2	
W1237	Dust cover	...	...	...	...	...	1	
T280	Circlip	...	...	...	...	...	1	
W1481	Grease retainer	...	...	...	...	...	1	
W3337	Bearing support ring	...	...	...	...	...	1	
W582	Retaining ring	...	...	...	...	...	1	
W1992	Cover plate	...	...	...	...	...	1	
W2092	Screw (1/4 in. U.H.)	...	...	...	...	...	3	
E2351	Washer	...	...	...	...	...	3	
W1197	Balance weight 1/2 oz.	...	...	...	...	...		as required
W1198	Balance weight 1 oz.	...	...	...	...	...		as required
W1990	Brake anchor plate	...	...	...	...	...	1	
W1996	BRAKE SHOE c/w LINING	...	...	...	...	...	2	
W1998	Brake lining	...	...	...	...	...	2	} Not supplied separately
W2059	Brass rivet	...	...	...	...	...	14	
W2026	Abutment pad	...	...	...	...	...	2	
W135	Shoe return spring	...	...	...	...	...	2	
W2001	Brake cam	...	...	...	...	...	2	
W2000	Brake cam lever front	...	...	...	...	...	1	
14-0302	Nut	...	...	...	...	...	2	
W1999	Brake cam lever rear	...	...	...	...	...	1	
W2003	Rod assembly	...	...	...	...	...	1	
W2005	Fork end threaded	...	...	...	...	...	1	
14-0401	Locknut	...	...	...	...	...	1	
W3522	Lever return spring	...	...	...	...	...	1	
S1995	Anchor plate nut	...	...	...	...	...	1	
WF32	Pivot pin	...	...	...	...	...	2	
D2683	Split pin (1/8 in. x 3/8 in. long)	...	...	...	...	...	2	
S25-6	Plain washer	...	...	...	...	...	1	
W1991	Gauze	...	...	...	...	...	1	
S650	Taptite screw	...	...	...	...	...	3	
D2687	Split pin (1/8 in. x 7/8 in. long)	...	...	...	...	...	1	

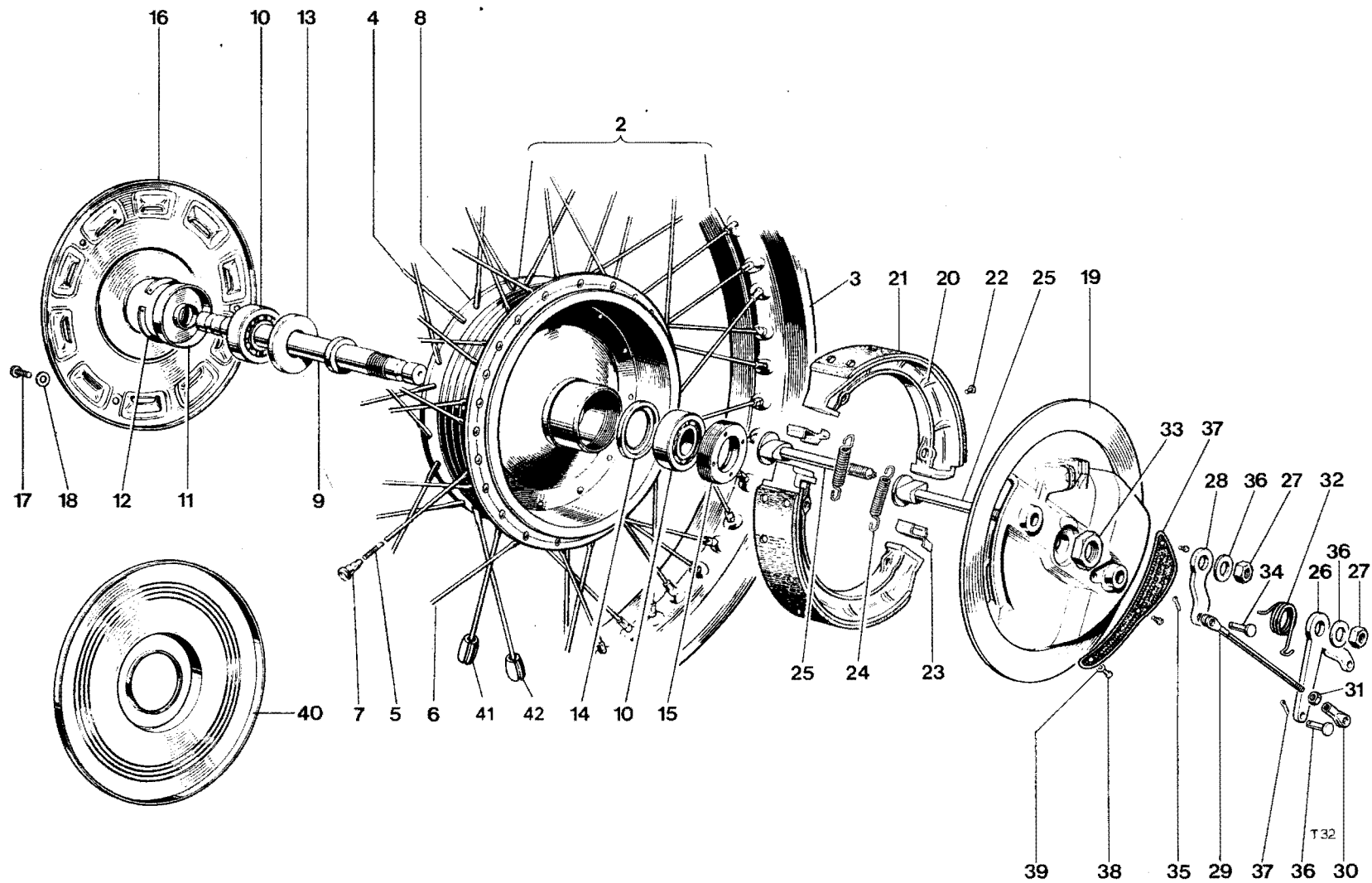

Fig. 21. FRONT WHEEL—LATE TYPE



## FRONT WHEEL (LATE TYPE)

Ref. No.	Part No.	DESCRIPTION	QUANTITY	REMARKS
1	W3509	FRONT WHEEL COMPLETE	1	
2	W1721	RIM, SPOKES AND HUB ASSEMBLY	1	
3	W1230	Front wheel rim (WM2-19)	1	
4	W1328	Spoke (8/10G x 5 $\frac{5}{8}$ in. straight)	20	
5	W1708	Spoke (8/10G x 4 $\frac{3}{4}$ in. 78°)	10	
6	W1709	Spoke (8/10G x 4 $\frac{7}{8}$ in. 100°)	10	
7	S79-2	Spoke nipple	40	
8	W1722	Hub and brake drum	1	
9	W3582	Wheel spindle	1	
10	W653	Bearing	2	
11	W1237	Dust cover	1	
12	T280	Circlip	1	
13	W3337	Bearing support ring	1	
14	W1481	Grease retainer	1	
15	W582	Retaining ring	1	
16	W1992	Cover plate	1	
17	W2092	Screw	3	
18	F2351	Plain Washer	3	
19	W3462	Brake anchor plate	1	
20	W1996	BRAKE SHOE c/w LINING	2	
21	Reference only	Brake lining	2	
22	Reference only	Brass rivet	16	
23	W2026	Abutment pad	2	
24	W135	Shoe return spring	2	
25	W2001	Brake cam	2	
26	W3453	Brake cam lever (front)	1	
27	14-0302	Nut	2	
28	W3454	Brake cam lever (rear)	1	
29	W2003	Rod	1	
30	W2005	Fork end, threaded	1	
31	14-0401	Locknut	1	
32	W3522	Lever return spring	1	
33	S1995	Anchor plate nut	1	
34	WF32	Pivot pin	2	
35	—	Split pin $\frac{1}{8}$ x $\frac{1}{2}$ in.	2	
36	S25-6	Plain washer	2	
37	W1991	Anchor plate gauze (for air scoop)	1	
38	S650	Taptite screw	3	
39	F2351	Plain washer	3	
40	W3460	Cover plate	1	Used on limited number of machines only, though will replace W1992 directly.
41	W1197	Balance weight, $\frac{1}{2}$ oz.	as required	
42	W1198	Balance weight, 1 oz.	as required	

REAR WHEEL COMPLETE  
№ 1

RIM, WHEEL SPOKES ASSEMBLY  
№ 2

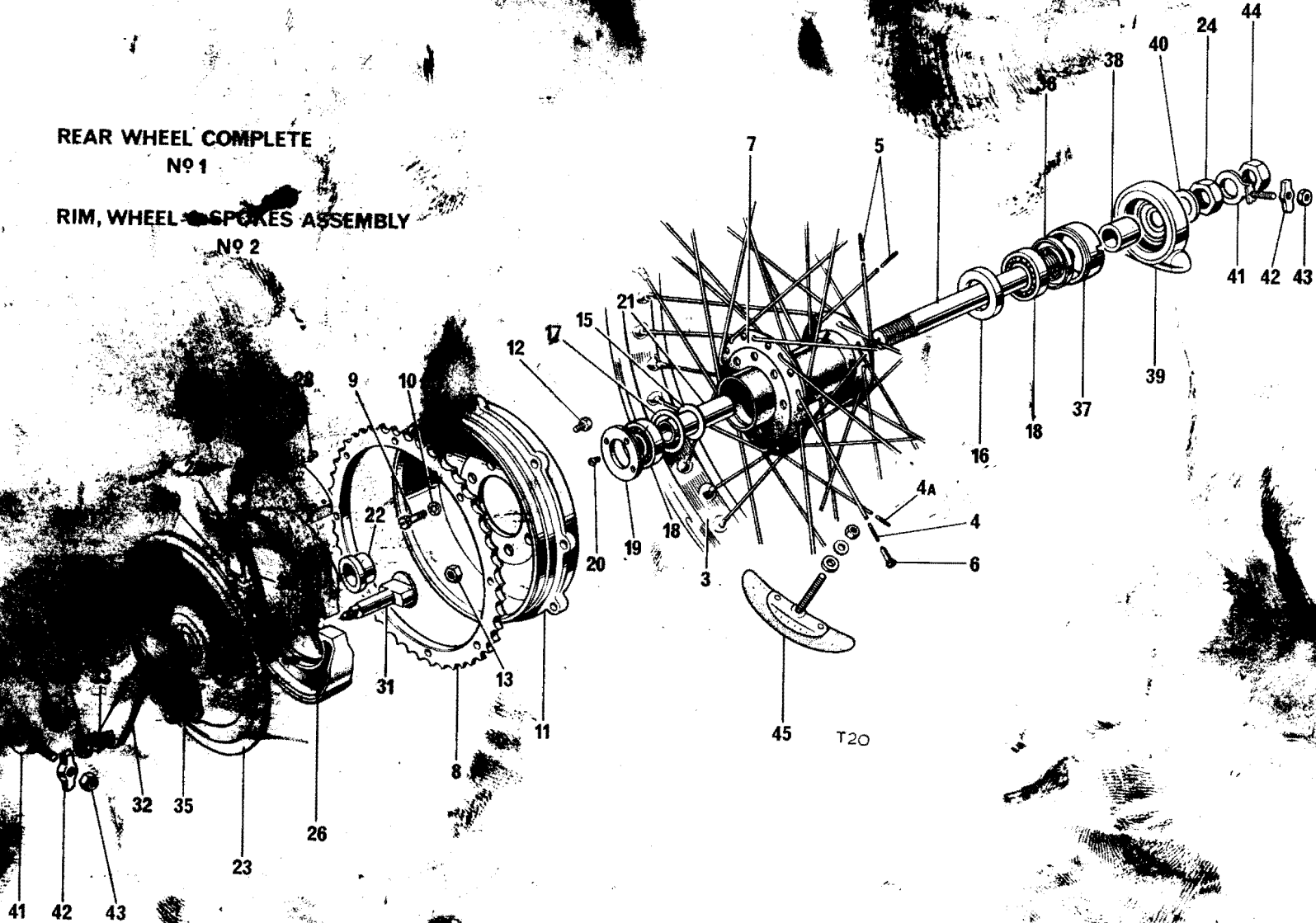

Fig. 22 REAR WHEEL

REAR WHEEL

Ref. No.	Part No.	DESCRIPTION	QUANTITY	REMARKS
1	W3427	REAR WHEEL COMPLETE ... ..	1	
2	W3428	RIM, SPOKES AND HUB ASSEMBLY ... ..	1	
3	W270A	Rear wheel rim W,3-19 ... ..	1	
4	W1104	Spoke D.S. ... ..	10	
4A	W3575	Spoke D.S. inner ... ..	10	
5	W1106	Spoke T.S. ... ..	20	
6	S79-2	Spoke nipple ... ..	40	
7	W1472	Hub ... ..	1	
8	*W3411	Sprocket 52T ... ..	1	
9	W1500	Bolt ( $\frac{1}{8}$ in. U.H.) ... ..	8	
10	E1612	Serrated washer ... ..	8	
11	W1498	Brake drum ... ..	1	
12	W1690	Bolt ( $\frac{1}{4}$ in. U.H.) ... ..	1	
13	W1691	Self locking nut ... ..	1	
14	W1281	Wheel spindle ... ..	1	
15	W1474	Grease retainer (brake side) ... ..	1	
16	W1654	Grease retainer ... ..	1	
17	W1022	Backing ring ... ..	1	
18	W653	Bearing ... ..	2	
19	99-0057	RETAINING RING ... ..	1	
20	W1710	Locking screw ( $\frac{5}{16}$ in. U.H.) ... ..	1	
21	W1278	Distance tube ... ..	1	
22	W1024	Distance piece ... ..	1	
23	W1112	Brake anchor plate ... ..	1	
24	W3426	Nut anchor inner T.S. ... ..	2	
25	W1406	LEADING BRAKE SHOE C/W LINING ... ..	1	
26	W1447	TRAILING BRAKE SHOE C/W LINING ... ..	1	
27	NW243	Brake lining ... ..	2	} Not serviced separately
28	W129	Brass rivet ... ..	16	
29	W1415	Thrust pad ... ..	2	
30	W135	Shoe return spring ... ..	2	
31	W1083	Brake cam ... ..	1	
32	W2015	Brake cam lever ... ..	1	
33	S25-6	Plain washer ... ..	1	
34	S1-52	Nut ... ..	1	
35	W1490	Lever return spring ... ..	1	
36	W1635	Grease retainer ... ..	1	
37	W1476	Speedometer adaptor ... ..	1	
38	W1477	Distance piece ... ..	1	
39	D637	Speedometer gearbox (MPH HEAD) ... ..	1	
40	W1280	Plain washer ... ..	1	
41	W2089	Rear wheel adjuster ... ..	2	
42	W1015	Adjuster end plate ... ..	2	
43	14-0902	Self locking nut ... ..	2	
44	F1747	Spindle nut outer T.S. and D.S. ... ..	2	
45	WM3	Tyre security bolt ... ..	2	
46	W3425	Inner nut D.S. ... ..	1	
47	W1467	Pivot pin ... ..	1	

\* 53T rear sprocket W3412 } Used on later  
 † Rear wheel C/W 53T sprocket W3583 } machines

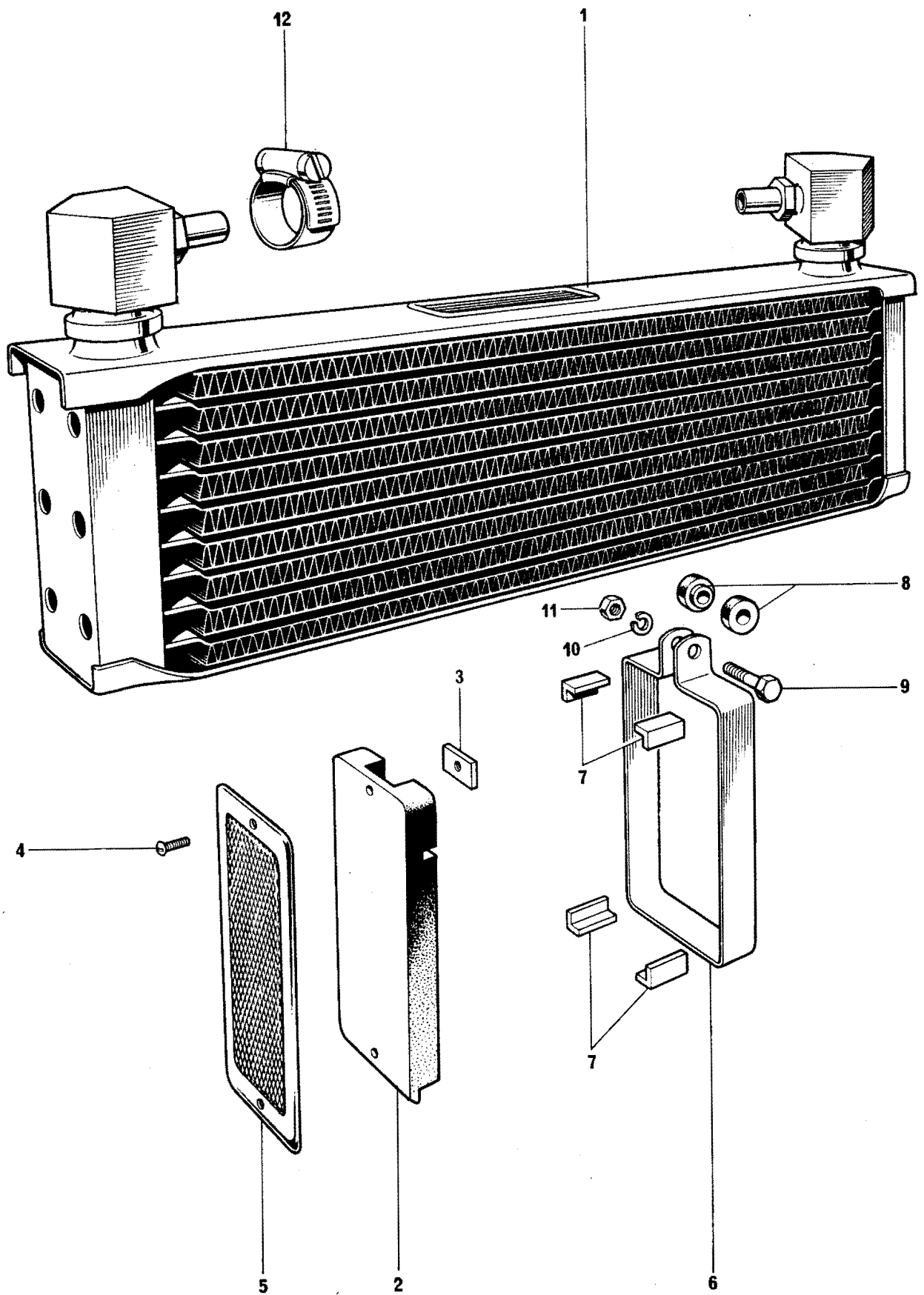

Fig. 23. OIL COOLER

## OIL COOLER GROUP

1	F9315	Oil cooler, including unions ... ..	1
2	F9907	Reflector rubber and plate ... ..	2
3	F9573	Reflector nut ... ..	4
4	S1940	Reflector screw ... ..	4
5	57160	Reflector ... ..	2
6	F9317	Support strap ... ..	2
7	F9322	Corner packing ... ..	8
8	F9321	Rubber bush ... ..	4
9	F9323	Clamp bolt ( $\frac{5}{16}$ in. U.H.) ... ..	2
10	E2351	Spring washer ... ..	2
11	F4717	Nut ... ..	2
12	D702	Clip ... ..	2

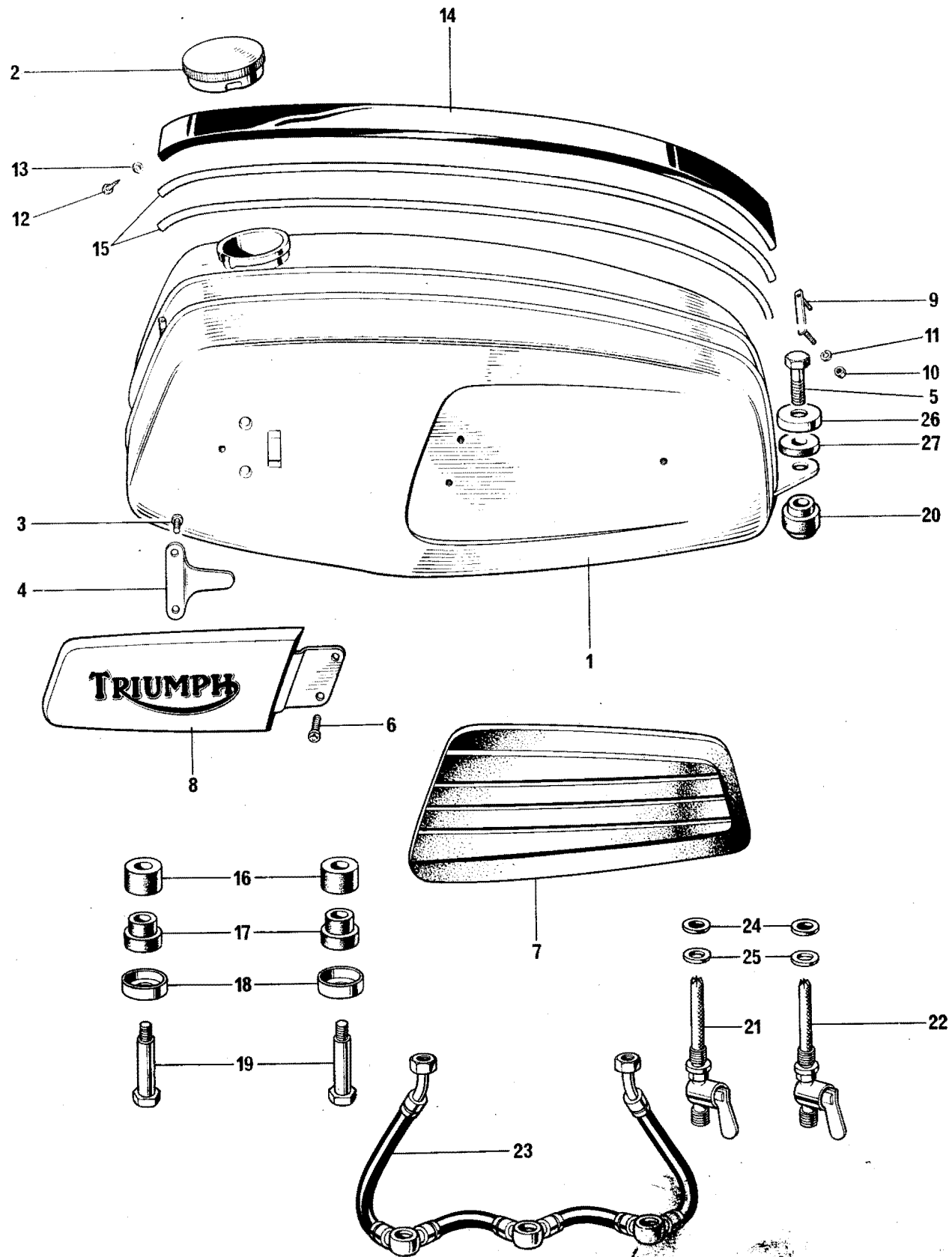

Fig. 24. PETROL (GAS) TANK

## PETROL (GAS) TANK

1	F11338	PETROL TANK	...	...	...	...	...	...	1
not illus.	A56	Transfer "World Record Holder"	...	...	...	...	...	...	1
not illus.	A61	Transfer "Made in England"	...	...	...	...	...	...	1
2	F3220	Filler Cap	...	...	...	...	...	...	1
3	S1804	Screw, tank motif clip ( $\frac{1}{4}$ in. U.H.)	...	...	...	...	...	...	4
4	F9381	Spring clip motif	...	...	...	...	...	...	2
5	F7388	Bolt for tank rear	...	...	...	...	...	...	1
6	F4715	Screw, motif ( $\frac{1}{32}$ in. U.H.)	...	...	...	...	...	...	4
7	F9372	Knee grip D.S.	...	...	...	...	...	...	1
7	F9373	Knee grip T.S.	...	...	...	...	...	...	1
8	F9360	Tank motif D.S.	...	...	...	...	...	...	1
8	F9361	Tank motif T.S.	...	...	...	...	...	...	1
9	F9449	Tensioner (for band)	...	...	...	...	...	...	1
10	H919	Nut	...	...	...	...	...	...	2
11	F4019	Spring washer	...	...	...	...	...	...	2
12	S1804	Screw	...	...	...	...	...	...	2
13	E2351	Washer	...	...	...	...	...	...	2
14	F9450	Centre band	...	...	...	...	...	...	1
15	F9451	Centre band beading	...	...	...	...	...	...	2
16	F5228	Top rubber (front support)	...	...	...	...	...	...	2
17	F9543	Spigotted rubber (front support)	...	...	...	...	...	...	2
18	F3814	Bottom cup (front support)	...	...	...	...	...	...	2
19	†F9446	Bolt (front support)	...	...	...	...	...	...	2
20	F5336	Rubber rear mounting...	...	...	...	...	...	...	1
21	F4971	Petrol tap (reserve) L.H.	...	...	...	...	...	...	1
22	F4972	Petrol tap (main) R.H.	...	...	...	...	...	...	1
23	F9436	Petrol pipe (assembly)	...	...	...	...	...	...	1
24	E7351	Tap seal	...	...	...	...	...	...	2
25	F10002	Steel washer	...	...	...	...	...	...	2
26	F3814	Cup for rear mounting	...	...	...	...	...	...	1
27	F967	Washer for rear tank fixing	...	...	...	...	...	...	1

†Later models use:—

S1883	Stud	...	...	...	...	...	...	...	2 off
14-1302	Nut	...	...	...	...	...	...	...	2 off

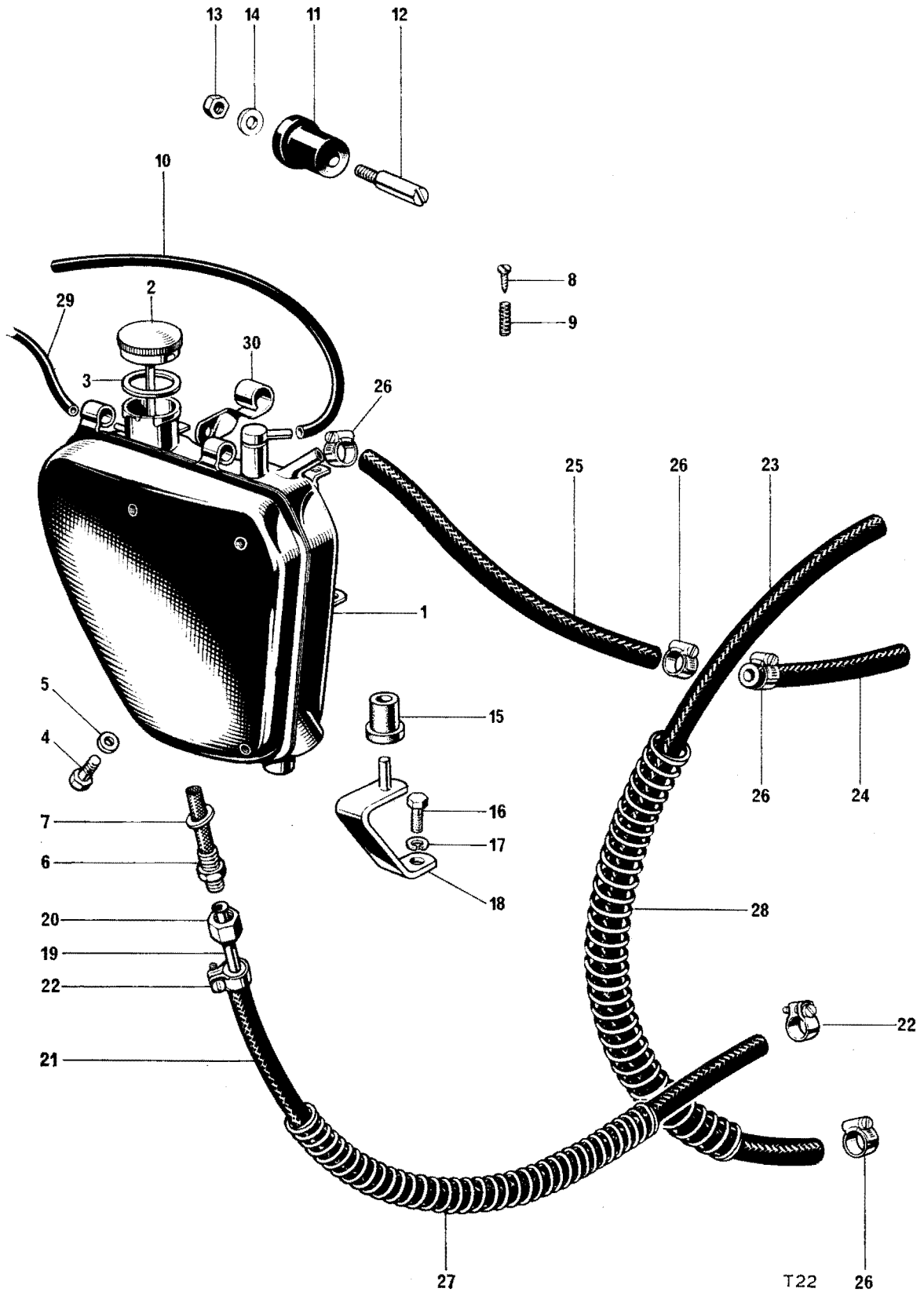

Fig. 25. OIL TANK



### OIL TANK

1	F9308	Oil tank ... ..	1	
Not illus.	A40 (D778)	Transfer (gilt) ... ..	1	
Not illus.	A44 (D44)	Transfer (gilt) ... ..	1	
Not illus.	A3	Transfer (gilt) ... ..	1	
2	F9659	Filler cap ... ..	1	
3	F4047	Joint washer ... ..	1	
4	F5343	Drain plug ... ..	1	
5	99-0048	Fibre washer ... ..	1	
6	F9430	Filter ... ..	1	
7	F1713	Fibre washer ... ..	1	
8	F9435	Metering screw ... ..	1	
9	F6874	Metering screw spring ... ..	1	
10	F9664	Extension pipe, froth tower ... ..	1	
11	F6673	Spigotted rubber ... ..	2	
12	F7510	Peg, tank to frame ... ..	2	
13	14-0301	Nut, tank to frame ... ..	2	
14	S25-13	Washer, tank to frame ... ..	2	
15	F6039	Bottom grommet ... ..	1	
16	S1822	Bottom bolt ( $\frac{1}{2}$ in. U.H.) ... ..	1	
17	S26-3	Spring washer ... ..	1	
18	F9588	Bottom bracket ... ..	1	
19	F3655	Oil feed pipe top half ... ..	1	
20	F3182	Union nut ... ..	1	
21	E8904	Oil pipe flex tank, to engine ... ..	1	
22	E6848	Oil pipe clip ... ..	2	
23	E8905	Oil pipe engine to oil cooler ... ..	1	
24	E8906	Rocker to oil cooler flexible pipe ... ..	1	
25	E8907	Cooler to oil tank flexible pipe ... ..	1	
26	D702	Clip oil return pipe ... ..	4	
27	F9530	Feed pipe protection spring ... ..	1	
28	F9531	Scavenge pipe spring ... ..	1	
29	F9526	Rear chain oiler pipe ... ..	1	
Not illus.	F9918	Clip, oil pipes to frame ... ..	1	
30	F11549	Clip for choke cable ... ..	1	

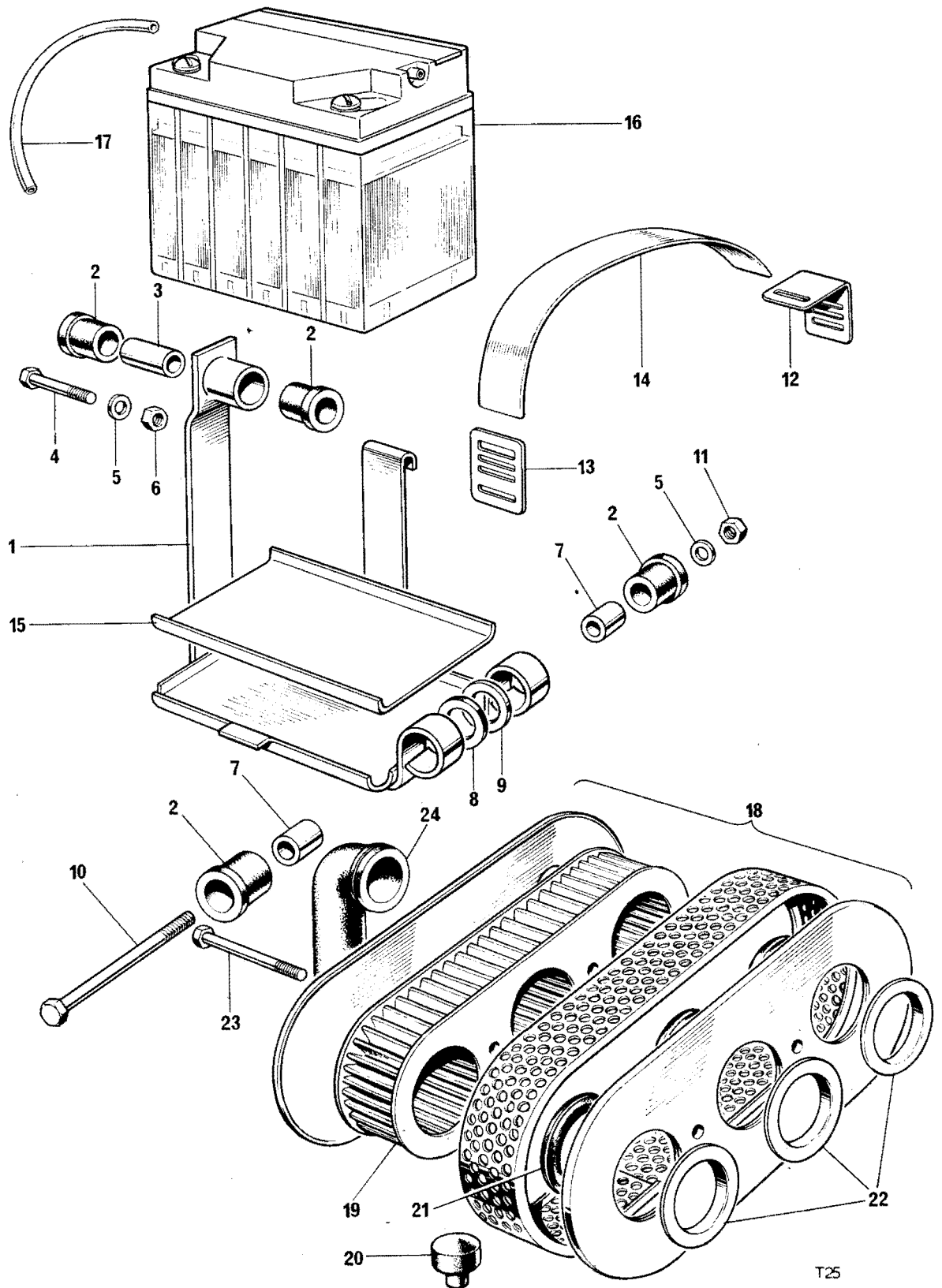

Fig. 26. BATTERY CARRIER AND AIR FILTER

**BATTERY CARRIER AND AIR FILTER**

1	F9343	Battery carrier	...	...	...	...	...	...	...	1
2	F9351	Spigotted rubber bush	...	...	...	...	...	...	...	4
3	F9349	Top distance tube	...	...	...	...	...	...	...	1
4	14-0221	Top bolt (2 in. U.H.)	...	...	...	...	...	...	...	1
5	S25-3	Washer	...	...	...	...	...	...	...	2
6	14-0302	Nut	...	...	...	...	...	...	...	1
7	F9350	Bottom distance tube	...	...	...	...	...	...	...	2
8	F9352	Rubber washer	...	...	...	...	...	...	...	2
9	F4299	Washer	...	...	...	...	...	...	...	2
10	14-0228	Bolt (4 in. U.H.)	...	...	...	...	...	...	...	1
11	14-0302	Nut	...	...	...	...	...	...	...	1
12	F9354	Strap buckle top	...	...	...	...	...	...	...	1
13	F9355	Strap buckle bottom	...	...	...	...	...	...	...	1
14	F9353	Retaining strap	...	...	...	...	...	...	...	1
15	F8091	Rubber battery tray	...	...	...	...	...	...	...	1
Not illus.	A52	Transfer, positive earth	...	...	...	...	...	...	...	1
16	99-0719	Battery PUZ5A (54027029)	...	...	...	...	...	...	...	1
17	F7431	Battery vent pipe	...	...	...	...	...	...	...	1
18	E9074	AIR CLEANER C/W ELEMENT	...	...	...	...	...	...	...	1
19	E9138	Element	...	...	...	...	...	...	...	1
20	F7835	Buffer	...	...	...	...	...	...	...	1
21	F9562	Grommet	...	...	...	...	...	...	...	3
22	E9586	Sleeve	...	...	...	...	...	...	...	3
23	14-0213	Bolt (3½ in. U.H.)	...	...	...	...	...	...	...	1
24	F9563	Connector hose	...	...	...	...	...	...	...	1

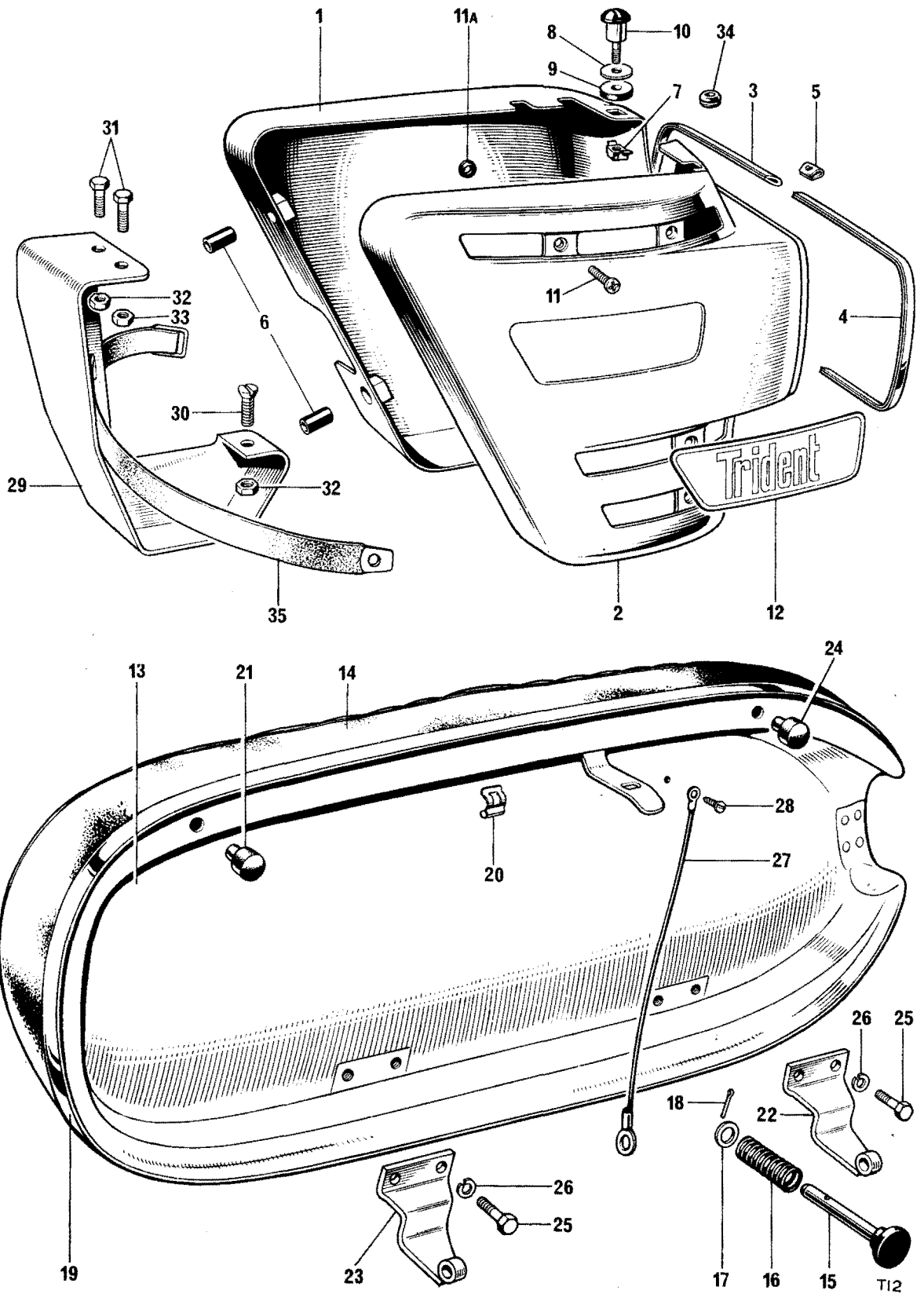

Fig. 27. PANELS AND TWINSEAT

**PANELS AND TWINSEAT**

1	F9362	D.S. Panel	1	
2	F9363	T.S. Panel	1	
3	F9591	Beading D.S.	1	
4	F9592	Beading T.S.	1	
5	F8631	Clip	6	
6	F6673	Grommet	2	
7	S1833	Caged nut	1	
8	S25-71	Washer	1	
9	F9442	Rubber spacer	1	
10	F9445	Release knob	1	
11	S1832	Screw T.S. panel to oil tank	4	
11A	F9442	Rubber	4	
12	D1905	Transfer 'Trident' D.S.	1	
12	D1906	Transfer 'Trident' T.S.	1	
13	F9996	TWINSEAT	1	
14	F9715	Twinseat cover	1	
15	F7560	Knob	1	
16	F4228	Spring	1	
17	E1719	Washer	1	
18	D2720	Split pin $\frac{3}{32}$ in. x $\frac{1}{2}$ in.	1	
19	D696	Trim strip	1	
20	D697	Sprag	4	
21	F4898	Buffer	1	
22	F8026	Front hinge	1	
23	F7862	Rear hinge	1	
24	F7835	Buffer	1	
25	14-0101	Bolt, hinge ( $\frac{1}{2}$ in. U.H.)	4	
26	S26-2	Spring washer	4	
27	D2087	Check wire	1	
28	F4483	Self tapping screw	1	
29	F9650	Toolbox	1	
30	14-0503	Screw, toolbox to battery carrier	1	
31	14-0101	Bolt	2	
32	14-0401	Nut	2	
33	14-1301	Nut	1	
34	F9770	Panel buffer	2	
35	F9749	Toolroll strap	1	

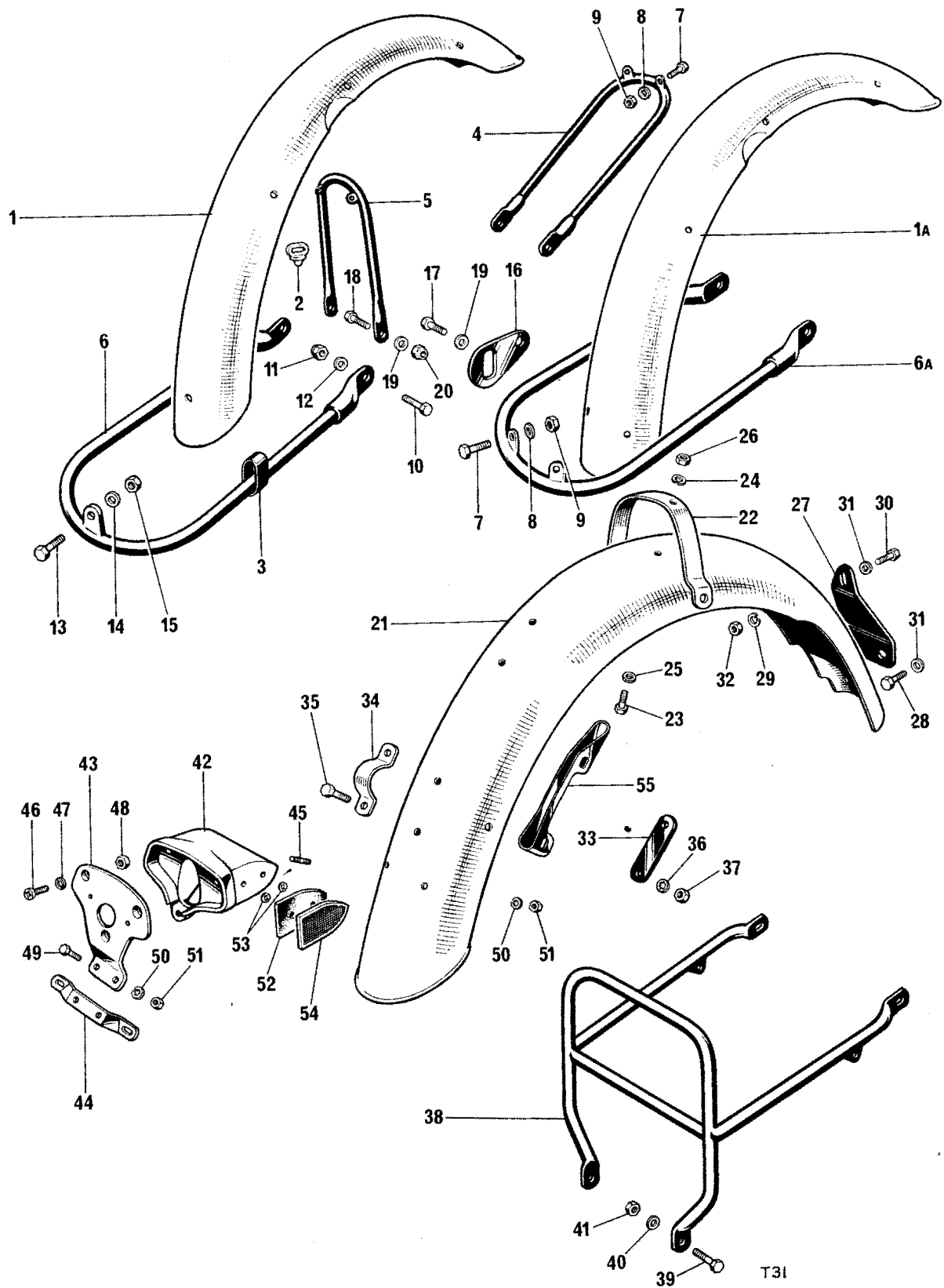

Fig. 28. MUDGUARDS (FENDERS)

## MUDGUARDS (FENDERS)

Ref. No.	Part No.	DESCRIPTION	QUANTITY	REMARKS
1	H2677	Front mudguard	1	
1A	H3881	Front mudguard	1	Later models
2	H2270	Brake cable retainer	1	
3	H2271	Sleeve	1	
4	H1681	Front stay	1	
5	H1683	Centre stay	1	
6	H3683	Bottom stay	1	
6A	H3885	Bottom stay	1	Later models
7	14-0101	Bolt ( $\frac{1}{2}$ in. U.H.)	4	Quantity 6 on later models
8	S25-1	Washer	4	
9	14 0201	Nut	4	
10	14-0115	Bolt (bottom stay to fork) ( $\frac{7}{8}$ in. U.H.)	2	
11	14-0702	Nut (bottom stay to fork)	2	
12	S25-3	Washer, bottom stay to fork	2	
13	S1822	Bolt (bottom stay to guard) ( $\frac{1}{2}$ in. U.H.)	1	Not fitted to later models
14	S25-3	Washer	1	
15	14-1302	Nut, bottom stay to guard	1	
16	H1685	Bracket, stays to fork leg	2	
17	S1822	Bolt, stays to fork leg ( $\frac{1}{2}$ in. U.H.)	2	
18	14-0115	Bolt, stays to bracket ( $\frac{5}{8}$ in. U.H.)	2	
19	F4299	Washer, stays to bracket	2	
20	14-1302	Nut, stays to bracket	2	
21	F9310	Rear mudguard	1	
22	F6915	Bridge	1	
23	14-0102	Bolt, bridge ( $\frac{5}{8}$ in. U.H.)	2	
24	F6310	Washer, bridge	2	
25	S25-1	Washer	2	
26	14-1201	Nut	2	
27	F6851	Bracket (bottom front)	1	
28	S1822	Bolt bracket (bracket to pivot lug) ( $\frac{1}{2}$ in. U.H.)	2	
29	S25-1	Plain washer	3	
30	14-0101	Bolt (bracket to guard) ( $\frac{1}{2}$ in. U.H.)	1	
31	F6310	Washer	1	
32	14-1201	Nut	1	
33	F6031	Backing plate	1	
34	F5994	Top clip (guard to frame rail)...	1	
35	S1822	Bolt ( $\frac{1}{2}$ in. U.H.)	2	
36	S25-3	Washer	2	
37	14-1302	Nut	2	
38	F9356	Lifting handle	1	
39	14-0114	Bolt ( $\frac{5}{8}$ in. U.H.)	2	

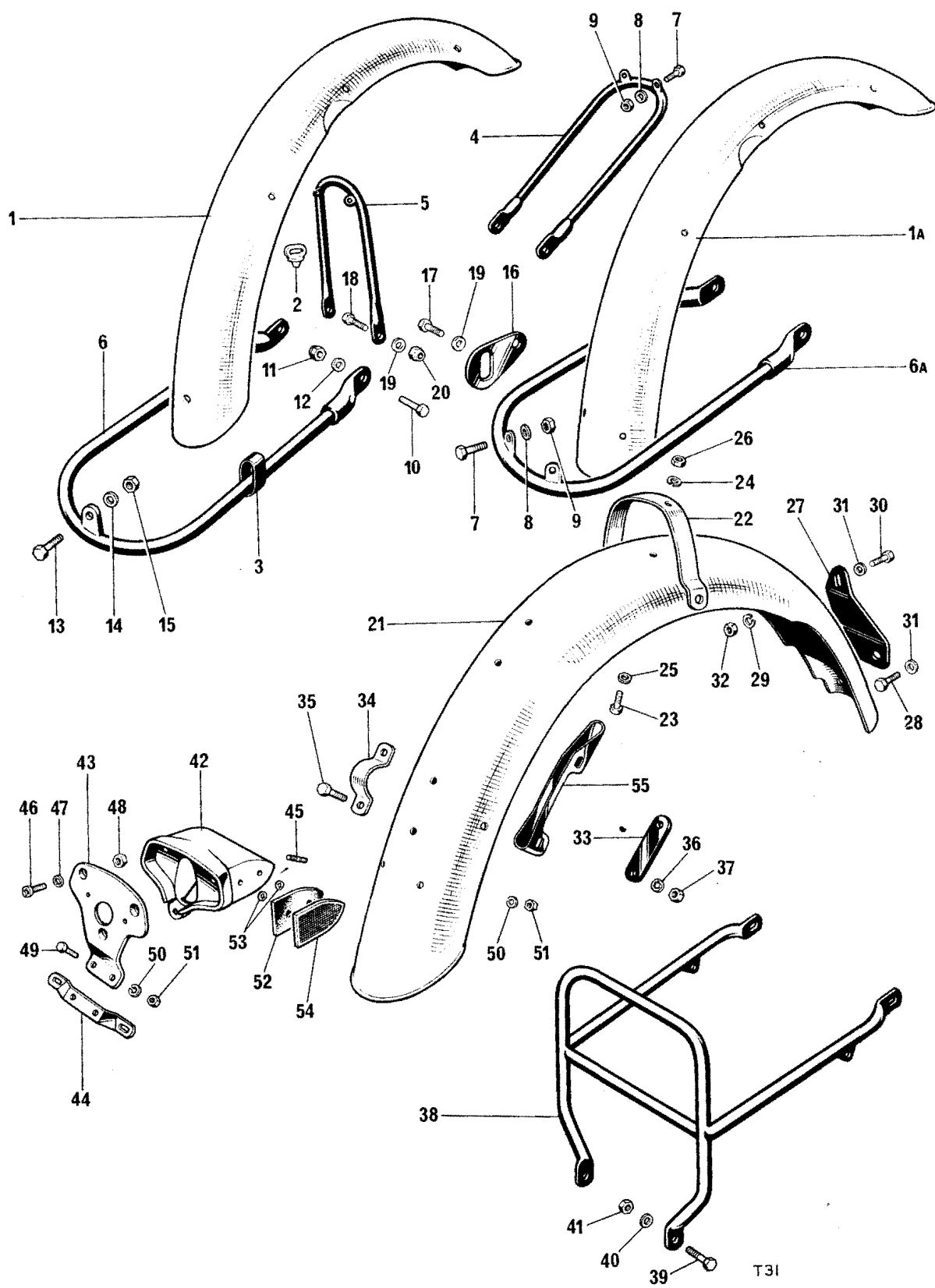

Fig. 29. MUDGUARDS (FENDERS)



## MUDGUARDS (FENDERS) continued

40	F1335	Plain washer	...	...	...	...	...	...	...	2
41	14-0702	Nut	...	...	...	...	...	...	...	2
42	F9327	Tail lamp support	...	...	...	...	...	...	...	1
43	F6849	Tail lamp support plate	...	...	...	...	...	...	...	1
44	F6850	Number plate bracket	...	...	...	...	...	...	...	2
45	S547	Stud ( $\frac{7}{8}$ in. U.H.)	...	...	...	...	...	...	...	1
46	F4715	Screw, plate to support	...	...	...	...	...	...	...	3
47	GS299	Shakeproof washer	...	...	...	...	...	...	...	1
48	S5161	Nut	...	...	...	...	...	...	...	1
49	14-0102	Bolt (lamp bracket to guard) ( $\frac{1}{2}$ in. U.H.)	...	...	...	...	...	...	...	4
50	S25-1	Washer	...	...	...	...	...	...	...	5
51	14-1301	Nut	...	...	...	...	...	...	...	5
52	F8140	Rubber mat, reflector	...	...	...	...	...	...	...	2
53	F8195	Push fix	...	...	...	...	...	...	...	4
54	F8873	Red reflector (57111)	...	...	...	...	...	...	...	2
55	F7862	Wiring protector	...	...	...	...	...	...	...	1

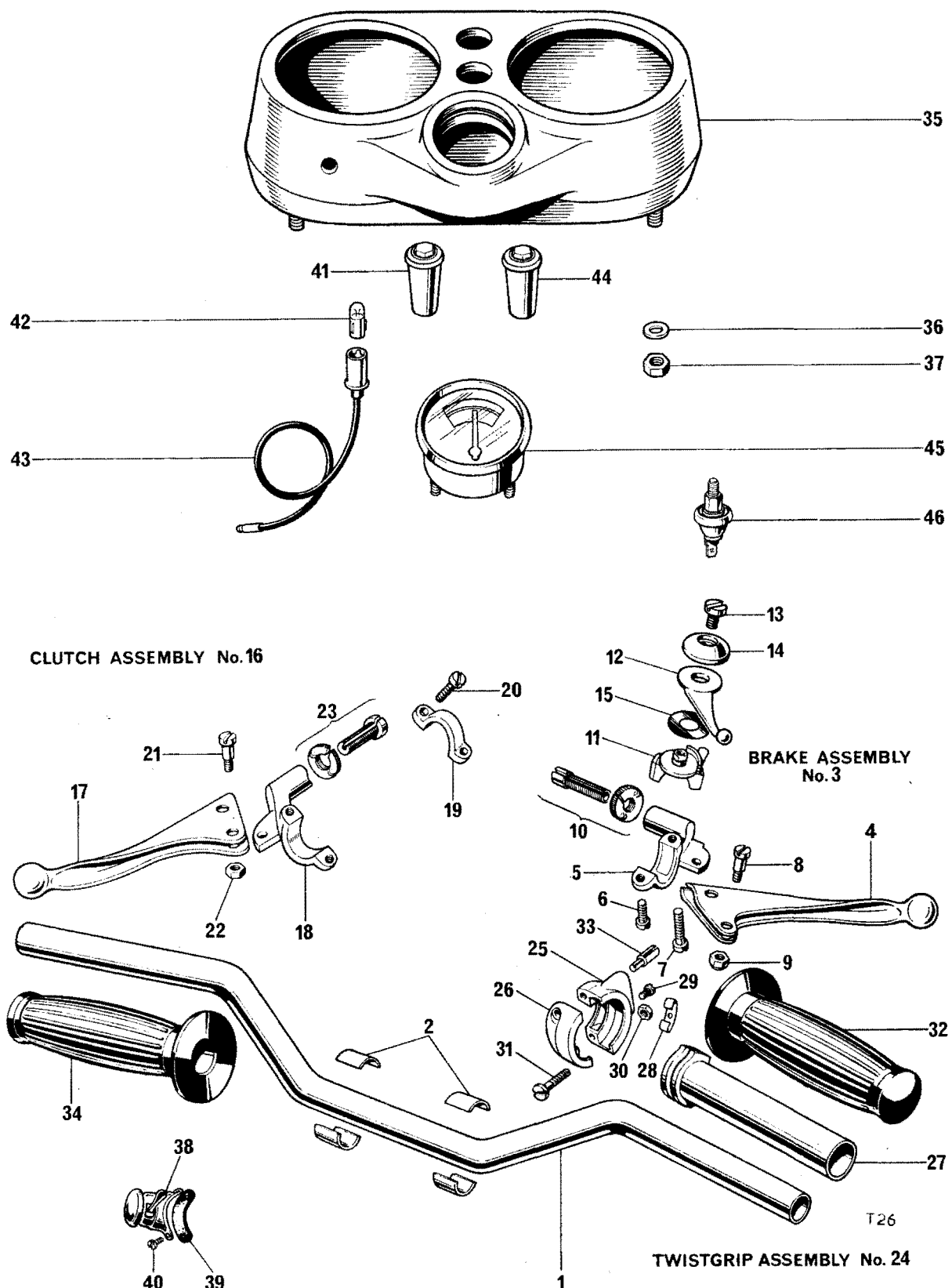

Fig. 30. HANDLEBARS, CONTROLS, BINNACLE AND OIL WARNING LIGHT

**HANDLEBAR, BINNACLE, CONTROL LEVERS, OIL WARNING LIGHT**

1	H1870	Handlebar ... ..	1
2	H1425	Packing piece ... ..	4
3	D2073	FRONT BRAKE LEVER ASSEMBLY (18/978)	1
4	99-0262	Front lever (ball end) 18/754 ... ..	1
5	99-0267	Lever bracket 18/777 ... ..	1
6	99-0226	Screw 11/014 ... ..	1
7	99-0225	Screw 11/013 ... ..	1
8	99-0252	Fulcrum screw 18/087 ... ..	1
9	99-0250	Self locking nut 18/053 ... ..	1
10	99-1031	Cable adjuster and nut 18/1708/1709 ... ..	1
11	99-0234	Control body (12/619) ... ..	1
12	99-0228	Lever 12/556 ... ..	1
13	12/607	Bolt 12/607 ... ..	Reference only
14	12/606	Cap 12/606 ... ..	Reference only
15	12/033	Spring washer 12/033 ... ..	Reference only
16	99-D2134	CLUTCH LEVER ASSEMBLY 18/973	1
17	99-1101	Clutch lever (ball end) 18/753 ... ..	1
18	99-0265	Clutch lever bracket 18/820 ... ..	1
19	99-0230	Clamp 12/595 ... ..	1
20	99-0226	Screw 11/014 ... ..	2
21	99-0252	Fulcrum screw 18/087 ... ..	1
22	99-0250	Self locking nut 18/053 ... ..	1
23	99-1031	Cable adjuster and nut 18/1708/1709 ... ..	1
24	99-1102	TWISTGRIP (364/011)...	1
25	364/013	Body top half ... ..	1
26	364/014	Body bottom half ... ..	1
27	364/017	Rotor ... ..	1
28	99-0238	Friction spring 16/008 ... ..	1
29	99-0239	Friction spring screw 16/009 ... ..	1
30	99-0240	Locknut 16/010 ... ..	1
31	99-0225	Screw 11/013 ... ..	2
32	H2125	Grip (black) ... ..	1
33	99-0241	Cable stop 16/011 ... ..	1
34	D2017	Grip (black) ... ..	1
35	H2297	Binnacle ... ..	1
36	S25-1	Plain washer ... ..	4
37	14-1201	Nut ... ..	4
38	99-0555	Dip switch 31563 ... ..	1
39	99-0630	Mounting pad 380459 ... ..	1
40	H1994	Screw ... ..	2
41	99-0568	Warning light body (red) 38189 ... ..	1
42	99-0537	Bulb (2W.BA7S) 281 ... ..	2
43	54945043	Warning bulb holder 54945043 ... ..	Reference only
44	54361250	Warning light body (blue) 54361250... ..	Reference only
45	D1992	Ammeter type 2AR 36421 ... ..	1
46	D2133	Oil Warning light switch (5307/05) ... ..	1

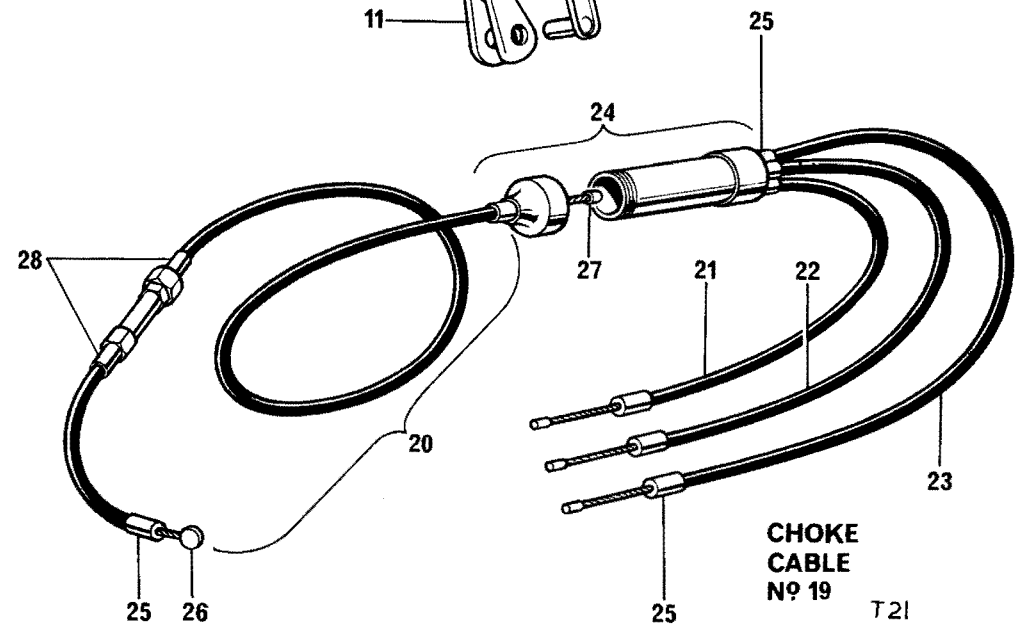
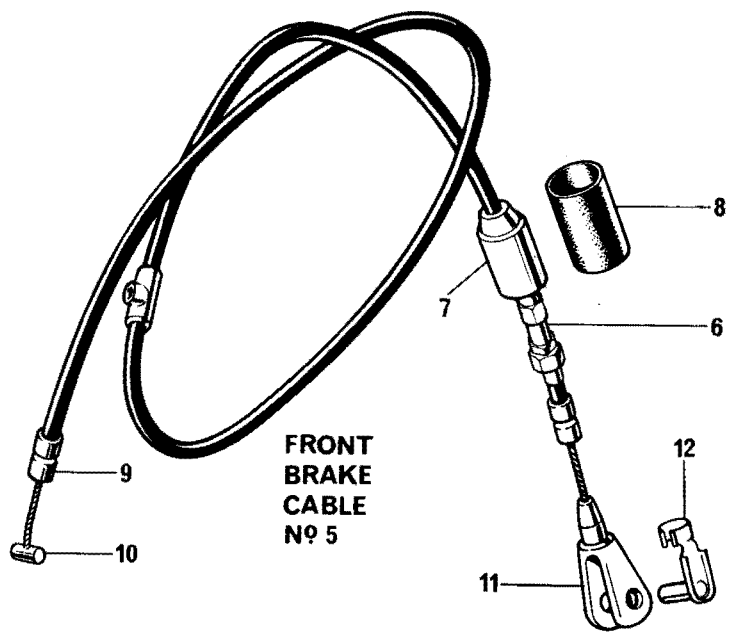
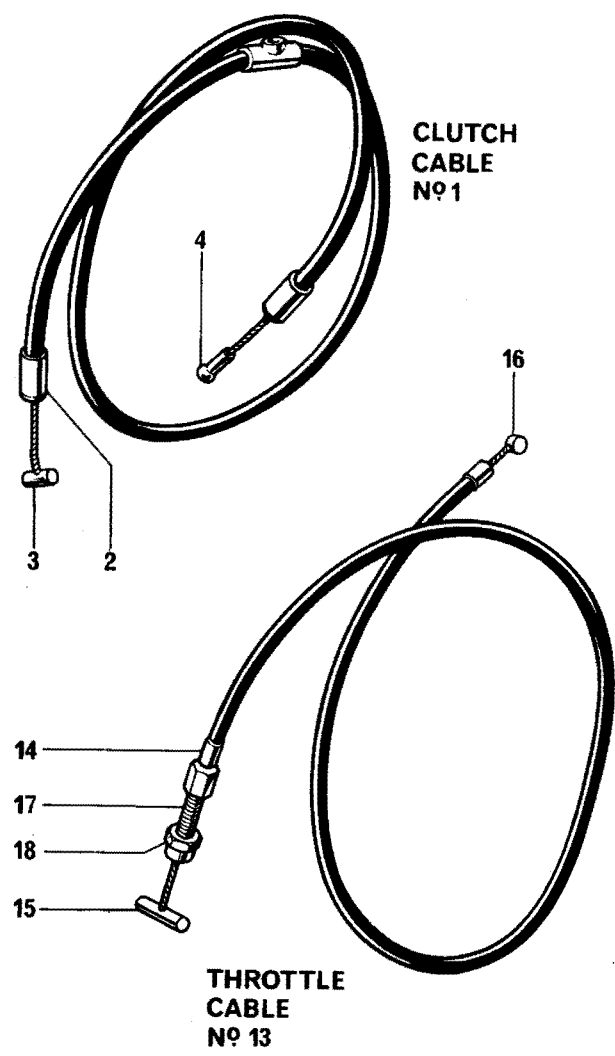

Fig. 31. CONTROL CABLES

## CONTROL CABLES

1	D2227	CLUTCH CABLE	...	...	...	...	...	...	...	1
2	D103	Ferrule	...	...	...	...	...	...	...	2
3	D506	Nipple, handlebar end	...	...	...	...	...	...	...	1
4	DS73	Nipple, clutch end	...	...	...	...	...	...	...	1
5	D2076	FRONT BRAKE CABLE	...	...	...	...	...	...	...	1
6	D2115	Adjuster c/w locknut	...	...	...	...	...	...	...	1
7	D2085	Stop switch	...	...	...	...	...	...	...	1
8	D2086	Rubber sleeve	...	...	...	...	...	...	...	1
9	D103	Ferrule	...	...	...	...	...	...	...	1
10	D506	Nipple, handlebar end	...	...	...	...	...	...	...	1
11	D638	Fork end, cable	...	...	...	...	...	...	...	1
12	W2006	Spring fix	...	...	...	...	...	...	...	1
13	D890	THROTTLE CABLE	...	...	...	...	...	...	...	1
14	D101	Ferrule	...	...	...	...	...	...	...	2
15	D83	Nipple	...	...	...	...	...	...	...	1
16	D2019	Nipple	...	...	...	...	...	...	...	1
17	D2018	Adjuster	...	...	...	...	...	...	...	1
18	E9253	Locknut	...	...	...	...	...	...	...	1
19	D1983	CHOKE CABLE COMPLETE...	...	...	...	...	...	...	...	1
20	D1968	Cable lever to junction box	...	...	...	...	...	...	...	1
21	D2062	Cable, junction box to carburetter, short	...	...	...	...	...	...	...	1
22	D2061	Cable, junction box to carburetter, medium	...	...	...	...	...	...	...	1
23	D2060	Cable, junction box to carburetter, long	...	...	...	...	...	...	...	1
24	99-1018	Junction box complete 244/2080	...	...	...	...	...	...	...	1
25	D101	Ferrule	...	...	...	...	...	...	...	10
26	D83	Nipple at handlebar	...	...	...	...	...	...	...	1
27	NS191	Nipple at junction box and carburetter	...	...	...	...	...	...	...	7
28	D1968	Adjuster complete	...	...	...	...	...	...	...	1

Models without  
the front stop  
switch use cable  
No. D2050

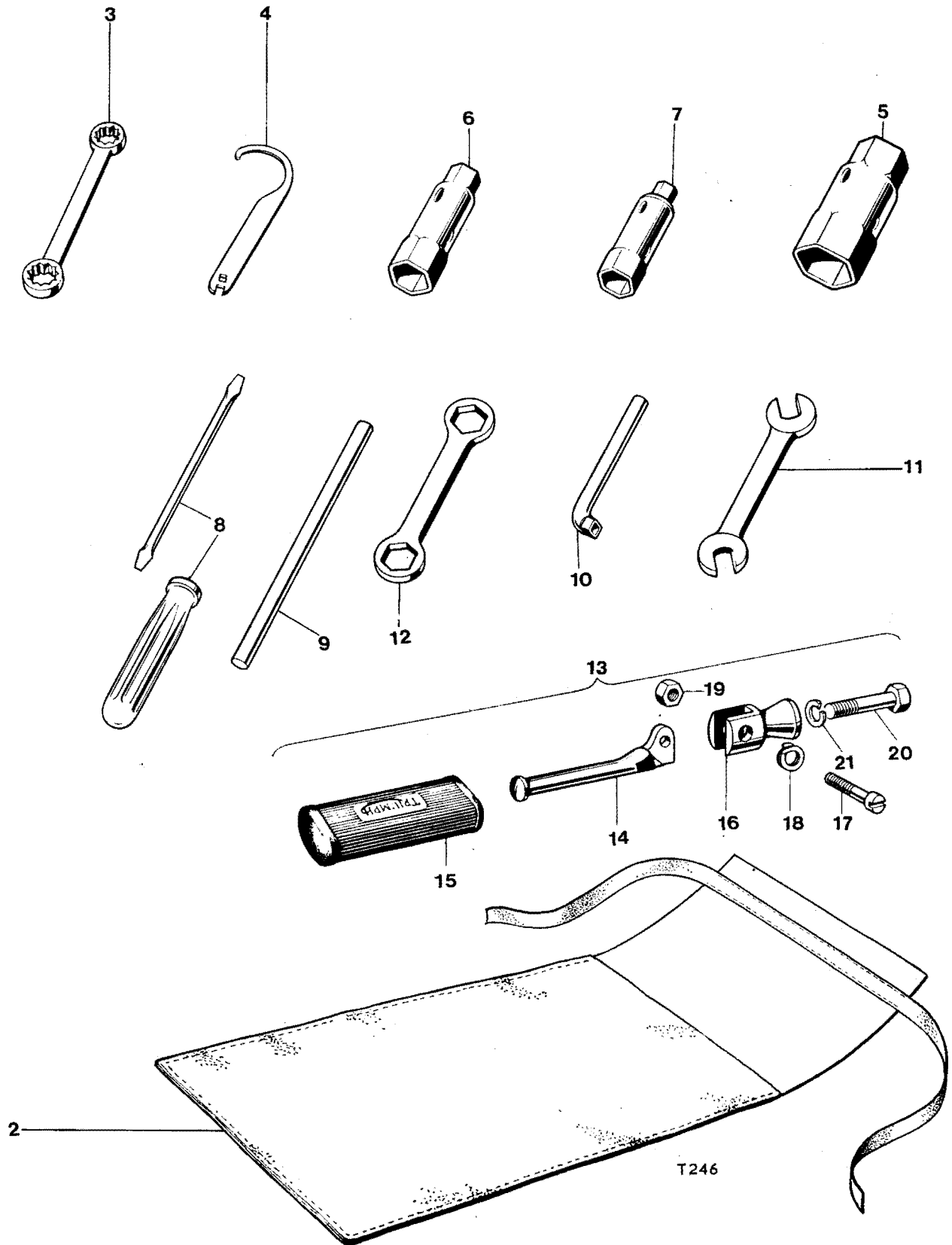
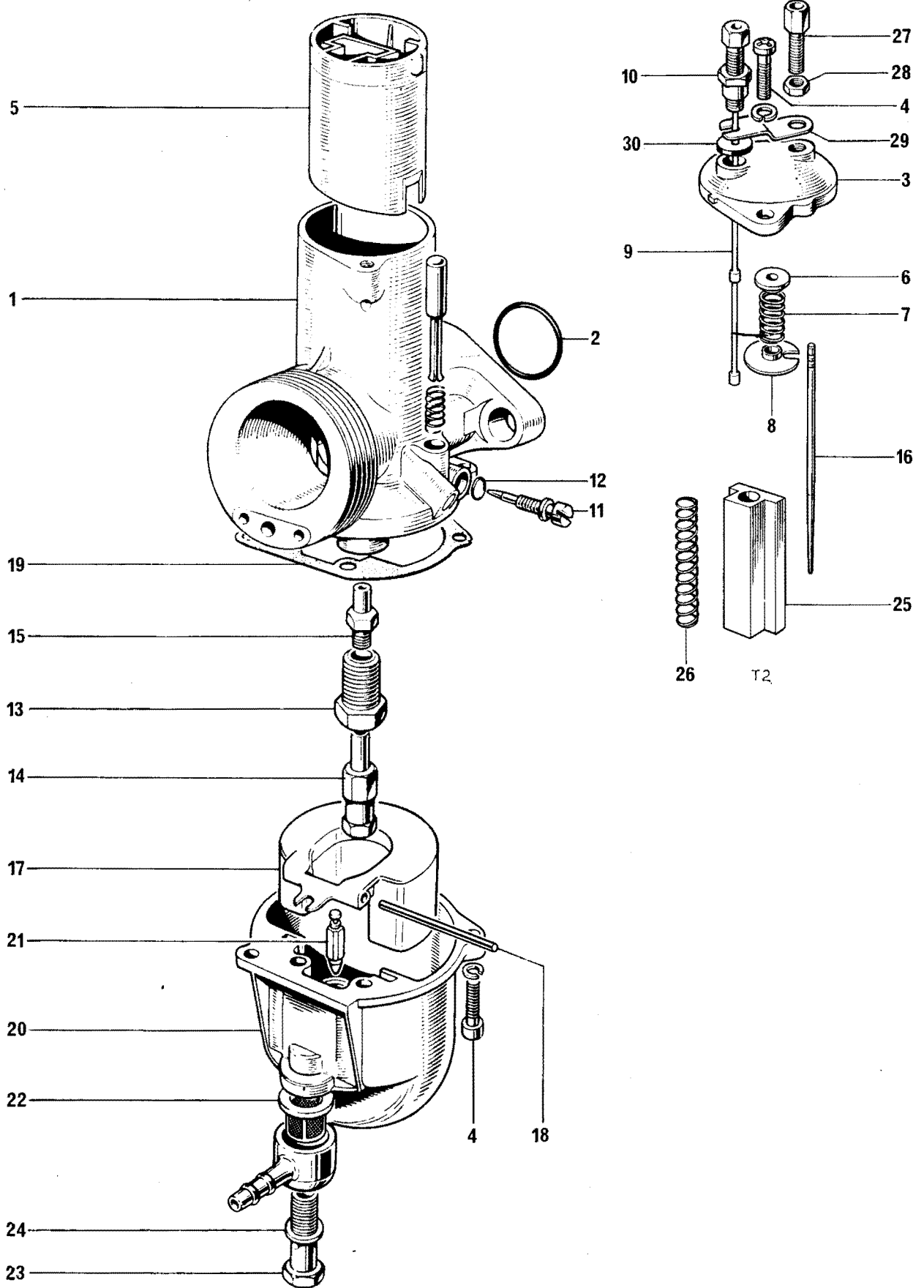

Fig. 32. TOOLKIT AND PILLION FOOTREST

**TOOLKIT AND PILLION FOOTRESTS**

Ref. No.	Part No.	DESCRIPTION	QUANTITY	REMARKS
1	D1912	TOOLKIT COMPLETE	1	
2	D291	Tool roll	1	
3	D1907	Ring spanner ( $\frac{7}{16}$ in. x $\frac{1}{2}$ in. HEX.)	1	
4	D2184	"C" spanner	1	
5	D1908	Box spanner ( $1\frac{1}{8}$ in. x $1\frac{5}{16}$ in.)	1	
6	D1909	Box spanner ( $\frac{5}{8}$ in. x $1\frac{1}{8}$ in.)	1	
7	D1910	Plug spanner	1	
8	D767	Screwdriver complete	1	
9	D1911	Tommy bar	1	
10	D2020	Tappet spanner	1	
11	D2084	Spanner $\frac{1}{2}$ in. x $\frac{7}{8}$ in. open ended	1	
12	D311	Ring spanner $\frac{5}{8}$ in. x $1\frac{1}{8}$ in. Hex.	1	
13	F9369	PILLION FOOTREST ASSEMBLY	2	
14	F1694	Pedal	2	
15	F1695	Rubber	2	
16	F9370	Hanger	2	
17	F9371	Pivot bolt	2	
18	F2277	Thackeray washer	2	
19	14-0302	Locknut	2	
20	14-0127	Bolt (rest to silencer hanger) ( $\frac{7}{8}$ in. U.H.)	2	
21	S26-1	Spring washer	2	

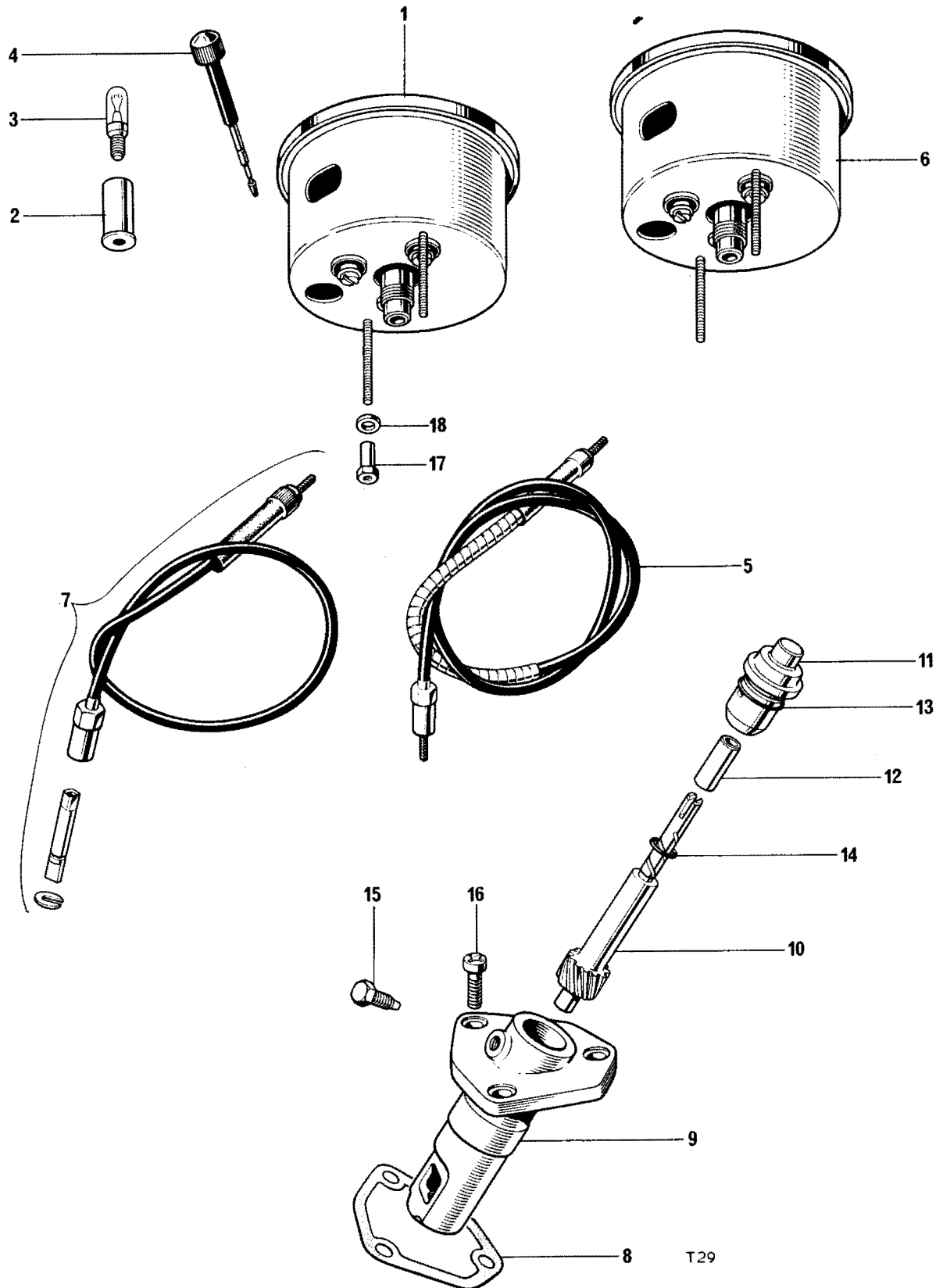

**Fig. 33. AMAL CARBURETTER AND AIR CLEANER CONNECTIONS**



## AMAL CARBURETTERS

1	D1957	CARBURETTER TYPE 626 R.H. (Amal R626/16)	...	...	...	...	...	1
1	D1985	CARBURETTER CENTRE (Amal R626/14)	...	...	...	...	...	1
1	D1986	CARBURETTER L.H. (Amal L626/15)	...	...	...	...	...	1
2	99-0522	'O' ring seal 622/101	...	...	...	...	...	3
3	99-1019	Mixing chamber top 622/097	...	...	...	...	...	3
4	99-0521	Screw 622/086	...	...	...	...	...	12
5	99-0506	Throttle valve (No. 3) 622/060	...	...	...	...	...	3
6	D1959	Top spring abutment	...	...	...	...	...	3
7	D1960	Spring	...	...	...	...	...	3
8	D1987	Bottom spring abutment	...	...	...	...	...	3
9	D1984	Throttle rod assembly	...	...	...	...	...	3
10	E9253	Locknut	...	...	...	...	...	3
11	99-0515	Pilot air screw 622/076	...	...	...	...	...	3
12	99-0520	Friction 'O' ring 622/082	...	...	...	...	...	4
13	99-0519	Jet holder 622/128	...	...	...	...	...	3
14	99-1020	Main jet (150) 376/100	...	...	...	...	...	3
15	99-1035	Needle jet (106) 622/122	...	...	...	...	...	3
16	99-1036	Needle (Standard) 622/124	...	...	...	...	...	3
17	99-0512	Float 622/069	...	...	...	...	...	3
18	99-0513	Float spindle 622/071	...	...	...	...	...	3
19	99-0514	Joint washer 622/073	...	...	...	...	...	3
20	99-0506	Float chamber 622/050	...	...	...	...	...	3
21	99-0511	Float needle 622/068	...	...	...	...	...	3
22	99-0438	Filter (376/093)	...	...	...	...	...	3
23	99-0517	Banjo bolt (622/078)	...	...	...	...	...	3
24	99-1100	Fibre washer (13/163)	...	...	...	...	...	3
25	99-1021	Air slide 622/062	...	...	...	...	...	3
26	99-0509	Spring 622/065	...	...	...	...	...	3
27	99-1024	Cable adjuster 4/035	...	...	...	...	...	3
28	99-0224	Locknut 5/077	...	...	...	...	...	3
29	99-1022	Clip 622/125	...	...	...	...	...	3
30	99-1023	Sealing rubber 622/126	...	...	...	...	...	3



**Fig. 34. SPEEDOMETER AND TACHOMETER**

Ref. No. Part No.

DESCRIPTION

QUANTITY REMARKS

## SPEEDOMETER AND TACHOMETER

Ref. No.	Part No.	DESCRIPTION	QUANTITY	REMARKS
1	D1930	Speedometer head MPH (SSM5001/06)	1	(Was previously RSM 3003/09—similar but with different bulb-holder location)
1A	D2199	Speedometer head KPH (SSM5001/12)	1	Available
2	54953446	Bulb holder	1	Reference only
3	643	Bulb	2	
4	99-0176	Trip control 41-148-203-10	1	
5	D1963	Speedometer cable 68 in. long	1	
6	D1949	Tachometer head (RSM 3003/01)	1	
7	D1903	Tachometer cable	1	
8	E8739	Joint washer, tacho drive	1	
9	E8740	Housing tacho driven gear	1	
10	E8741	Driven gear	1	
11	E8742	Tacho bearing housing	1	
12	E6124	Bush	1	
13	E3309	'O' ring housing	1	
14	E6299	'O' ring, driven gear	1	
15	E8744	Locating screw, housing	1	
16	14-6605	Screw, housing to c/case ( $\frac{7}{8}$ in. U.H.)	3	
17	H3632	Sleeve nut, speedometer fixing	4	
18	GS308	Washer	4	

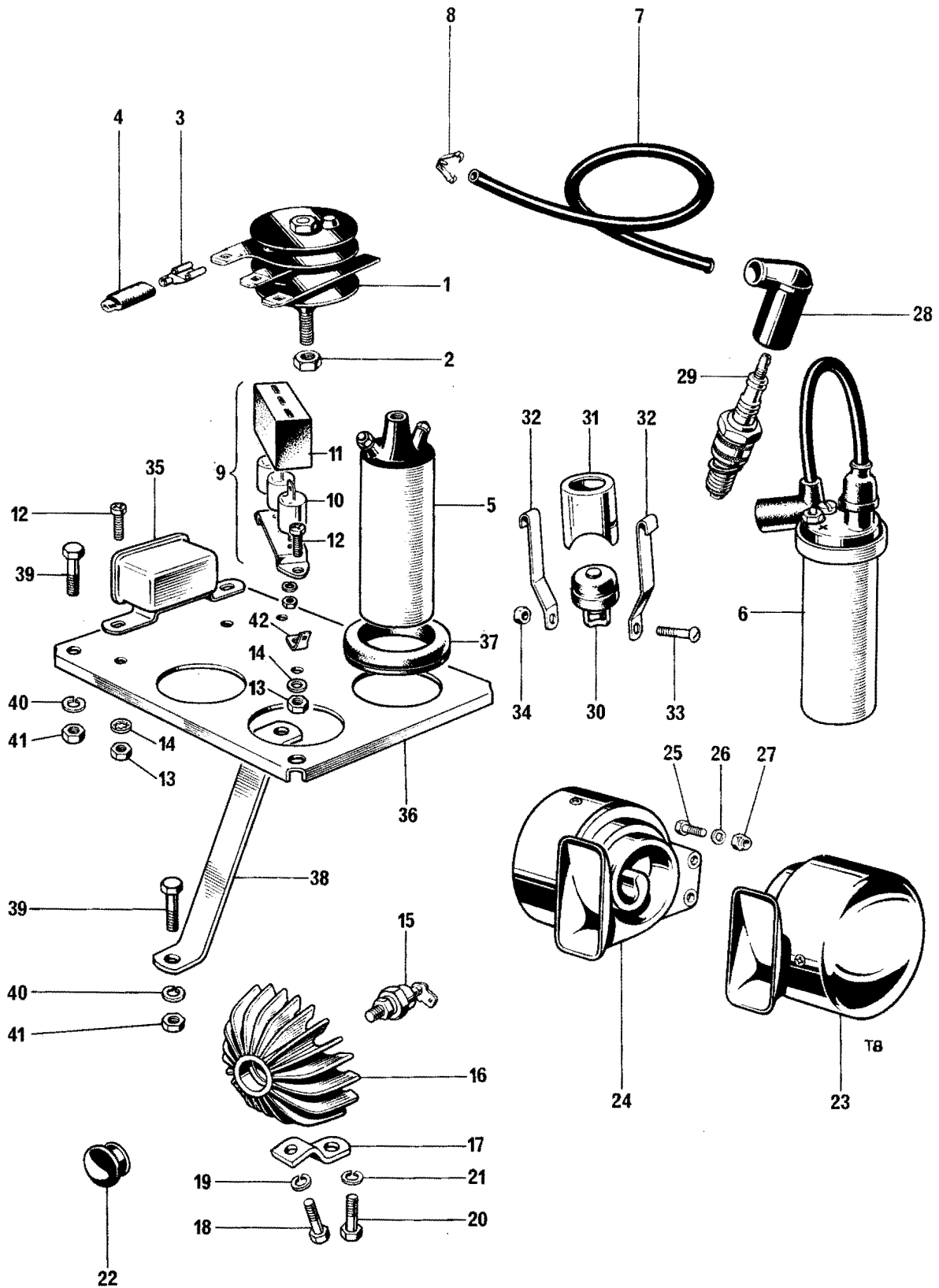

Fig. 35. IGNITION COILS, HORNS, RECTIFIER AND ZENER DIODE

**IGNITION COILS, HORNS, RECTIFIER ZENER DIODE**

1	D756	Rectifier (49072)	...	...	...	...	...	...	1	
2	F5338	Nut (156596)	...	...	...	...	...	...	1	
3	99-0799	Lucar connector 54942078	...	...	...	...	...	...	as required	
4	99-0738	Insulating cover 54190042	...	...	...	...	...	...	as required	
5	E6388	Ignition coil, Siba 32000	...	...	...	...	...	...	3	
6	D2203	Ignition coil Lucas 17M12 (45221)	...	...	...	...	...	...	3	Later models only
7	54956435	H.T. lead (7 mm. cable) NON RESISTIVE	...	...	...	...	...	...	3	For Lucas Coils
7	842189	H.T. lead (7 mm. cable) NON RESISTIVE	...	...	...	...	...	...	3	For SIBA Coils
8	99-0644	H.T. lead clip (421863)...	...	...	...	...	...	...	3	For Lucas Coils only
9	D1935	CAPACITOR PACK 3CP (47637)	...	...	...	...	...	...	1	
10	99-0766	Capacitor 54420128	...	...	...	...	...	...	3	
11	99-0767	Cover 54418528	...	...	...	...	...	...	1	
12	F10033	Screw pack to plate and relay to plate	...	...	...	...	...	...	5	
13	F3799	Nut	...	...	...	...	...	...	4	
14	GS299	Shakeproof washer	...	...	...	...	...	...	4	
15	99-0590	Zener diode 49345	...	...	...	...	...	...	1	
16	H2237	Heat sink	...	...	...	...	...	...	1	
17	H2236	Bracket (sink to fork lug)	...	...	...	...	...	...	1	
18	14-6102	Bolt (bracket to heat sink) ( $\frac{5}{8}$ in. U.H.)	...	...	...	...	...	...	1	
19	S26-2	Washer	...	...	...	...	...	...	1	
20	14-0113	Bolt bracket ( $\frac{5}{8}$ in. U.H.)	...	...	...	...	...	...	1	
21	S26-3	Washer	...	...	...	...	...	...	1	
22	H2275	Plug, heat sink	...	...	...	...	...	...	1	
23	D1900	Horn, R.H. Windtone (Clearhooter P201)	...	...	...	...	...	...	1	
24	D1901	Horn, L.H. Windtone (Clearhooter P101)	...	...	...	...	...	...	1	
25	14-0103	Bolt, horn to bracket ( $\frac{7}{8}$ in. U.H.)	...	...	...	...	...	...	4	
26	S25-1	Washer	...	...	...	...	...	...	4	
27	14-1201	Nut	...	...	...	...	...	...	4	
28	D1964	Spark plug cover	...	...	...	...	...	...	3	
29	D911	Spark plug N3	...	...	...	...	...	...	3	
30	D1937	Cut out switch type 151SA (35835)	...	...	...	...	...	...	1	
31	H2259	Cup	...	...	...	...	...	...	1	
32	H2034	Clip	...	...	...	...	...	...	2	
33	H687	Screw	...	...	...	...	...	...	1	
34	H745	Nut	...	...	...	...	...	...	1	
35	99-1022	Horn relay 33188	...	...	...	...	...	...	1	
36	F9564	Platform	...	...	...	...	...	...	1	
37	F9561	Grommet	...	...	...	...	...	...	3	
38	F9565	Platform stay	...	...	...	...	...	...	1	
39	14-0101	Bolt	...	...	...	...	...	...	4	
40	S26-2	Washer	...	...	...	...	...	...	4	
41	14-0301	Nut	...	...	...	...	...	...	4	
42	D2068	Lucar blade-condenser earth 54190038	...	...	...	...	...	...	1	

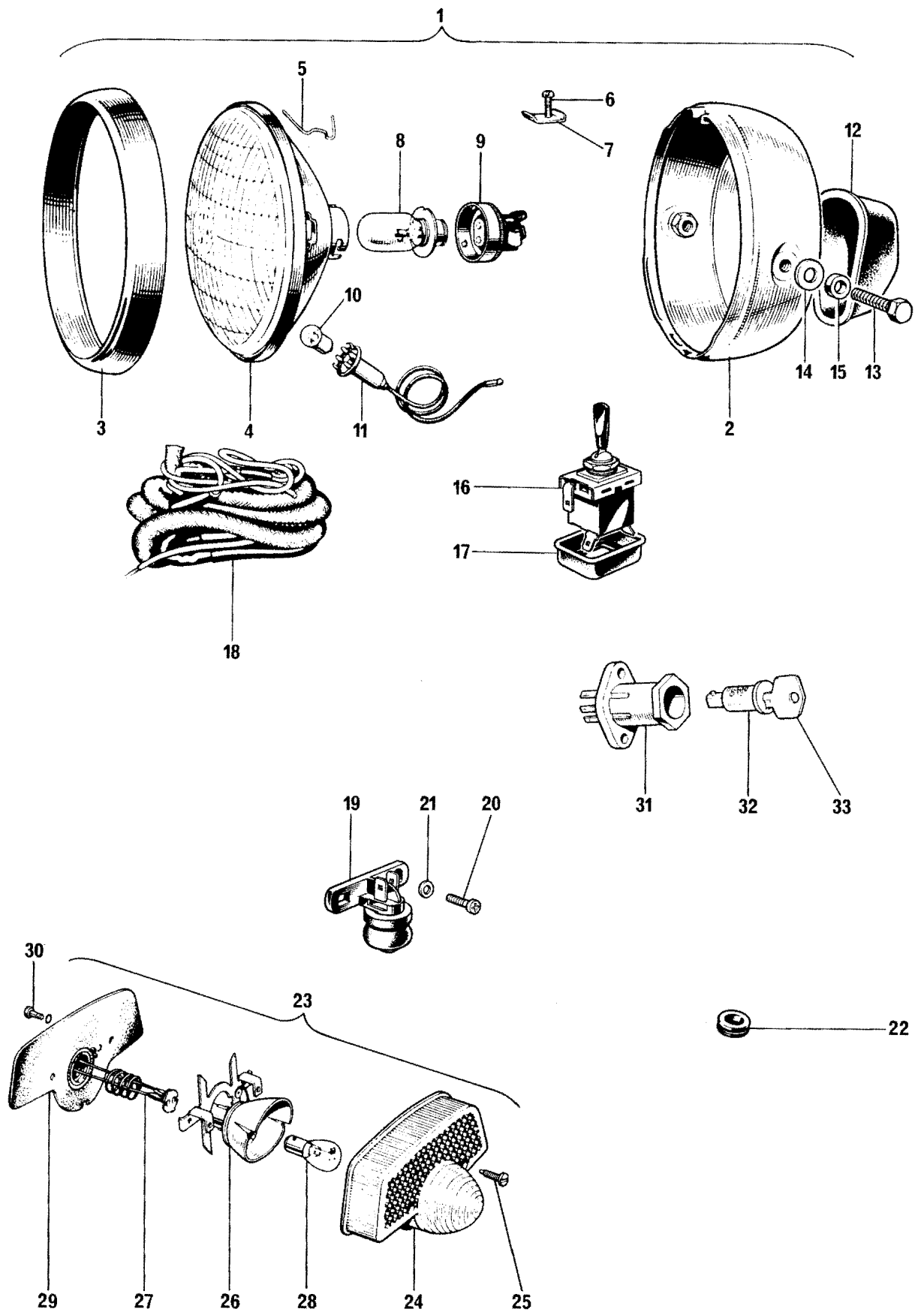

Fig. 36. HEADLAMP, WIRING HARNESS SWITCHES AND TAIL LAMP

## HEADLAMP, WIRING HARNESS, SWITCHES AND TAIL LAMP

Ref. No.	Part No.	DESCRIPTION	QUANTITY	REMARKS
1	99-1029	HEADLAMP COMPLETE MCH69 (59892)	1	
2	54524099	Shell 54524099	1	Reference only
3	99-0692	Rim 553248	1	
4	99-0686	Light unit 516798	1	
5	99-0683	Fixing wire 504665	6	
6	144921	Screw	1	Reference only
7	554408	Plate	1	Reference only
8	99-0545	Bulb (50/40W. vertical dip pre focus) 446	1	
9	99-1003	Main bulbholder 54520540	1	
10	99-0548	Bulb (6W. M.C.C.) 989	1	
11	99-0695	Pilot bulb holder 554710	1	
12	99-1026	Rubber cover 54524048	1	
13	112201	Bolt 112201	1	Reference only
14	137498	Plain washer 137498	1	Reference only
15	H1932	Distance piece	2	
16	99-0563	Lighting switch type 57SA (35710)	1	
17	F9692	Switch rubber cover	1	
18	D2124	Wiring harness 54955732	1	
19	99-1028	Stoplamp switch 118SA (34815)	1	
20	F4715	Screw, switch to engine plate ( $\frac{1}{32}$ in. U.H.)	1	
21	E2351	Washer, switch to engine plate	1	
22	199001	Rubber grommet (tail lead at guard) 199001	1	Reference only
23	99-0597	STOP AND TAIL LAMP, type L697 (53973)	1	
24	99-1046	Lens (54577109)	1	
25	144921	Screw	2	
26	54578213	Bulb holder with reflector	1	
27	99-0701	Contact assembly 573828	1	
28	99-0542	Bulb (6/21W. offset pin) 380	1	
29	99-0780	Gasket 54571677	1	
30	110714	Screw	1	Reference only
31	99-0558	Ignition switch, type S45 (31899)	1	
32	F6981	IGNITION LOCK C/W KEYS	1	
33	D622	Ignition key (state serial number)	2	
not illus.	H2262	Rubber cover, ignition switch	1	